



# Sorbent Trap Analysis with the Lumex RA-915M and RP-M324 Attachment

User Manual

Version 4.0 – April 2014



Ohio Lumex Company, Inc.  
9263 Ravenna Rd, unit A-3 Twinsburg, OH, USA  
Phone: 1 – 330 – 405-0837  
Email: [mail@ohiolumex.com](mailto:mail@ohiolumex.com)  
Web-site: [www.ohiolumex.com](http://www.ohiolumex.com)

## Table of Contents

<b>Section 1: Technology and Technical Specifications</b>	<b>4</b>
<b>Section 2: Getting Started</b>	<b>6</b>
2.1 Setting Up	6
2.2 Selecting and Running Temperature Profiles with EZ-ZONE RP-M324 controller	15
<b>Section 3: Launching RAPID Software</b>	<b>18</b>
<b>Section 4: Multi-Point Calibration &amp; Ladle Technique</b>	<b>21</b>
4.1 Manual Integration Calibration Method	21
4.2 Mark & Integrate Calibration Method	24
4.3 Analyzing Sorbent Trap Samples	28
<b>Section 5: Ladle Preparation</b>	<b>31</b>
<b>Section 6: Sample Preparation</b>	<b>34</b>
<b>Section 7: Maintenance</b>	<b>37</b>
<b>Appendix A: User Experiences</b>	<b>49</b>
<b>Appendix B: Coal, Ash &amp; Solids Analysis</b>	<b>51</b>
<b>Appendix C: Sorbent Trap Analysis Procedure</b>	<b>52</b>
<b>Appendix D: Determining the Method Detection Limit (MDL) for the Ohio Lumex RA-915+/RA-915M/RP-M324 Sorbent Trap Mercury Analyzers</b>	<b>75</b>
<b>Appendix E: Performing a Bias Test (Method 30B) and Spike Recovery Test (PS 12B) for the Ohio Lumex RA-915+/RA-915M/RP-M324 Sorbent Trap Mercury Analyzers</b>	<b>77</b>

<b>Appendix F:</b> Performing a Spike Recovery Study (PS-12B) on the Ohio Lumex RA-915M/RP-M324 Sorbent Trap Mercury Analyzer System_____	79
<b>Appendix G:</b> Tips to Streamline Sorbent Trap Analysis using Ohio Lumex_____	81
<b>Appendix H:</b> Tips for Successfully Using Method 30-B to Perform Mercury RATAs at Low-Level Sources_____	83
<b>Appendix I:</b> Method 30B Spiked Sample Calculations_____	92
<b>Appendix J:</b> SOP to calculate R squared per PS 12B and Method 30B requirements_____	94
<b>Appendix K:</b> Troubleshooting Sorbent Traps in case of Breakthrough and/or Spike Loss _____	95
<b>Appendix L:</b> Speciation Trap Analysis Procedure_____	97
<b>Appendix M:</b> Speciation Trap Standard Operating Procedure _____	125
<b>Appendix N:</b> Analyzing Coal, Ash, Soils, and Other Solids with the RA-915M/RP-M324Analyzer _____	131
<b>Product Warranty</b> _____	133
<b>Safety Data Sheet:</b> Sodium Carbonate _____	134
<b>Material Safety Data Sheet:</b> Activated Carbon _____	143

## Section 1: Technology and Technical Specifications

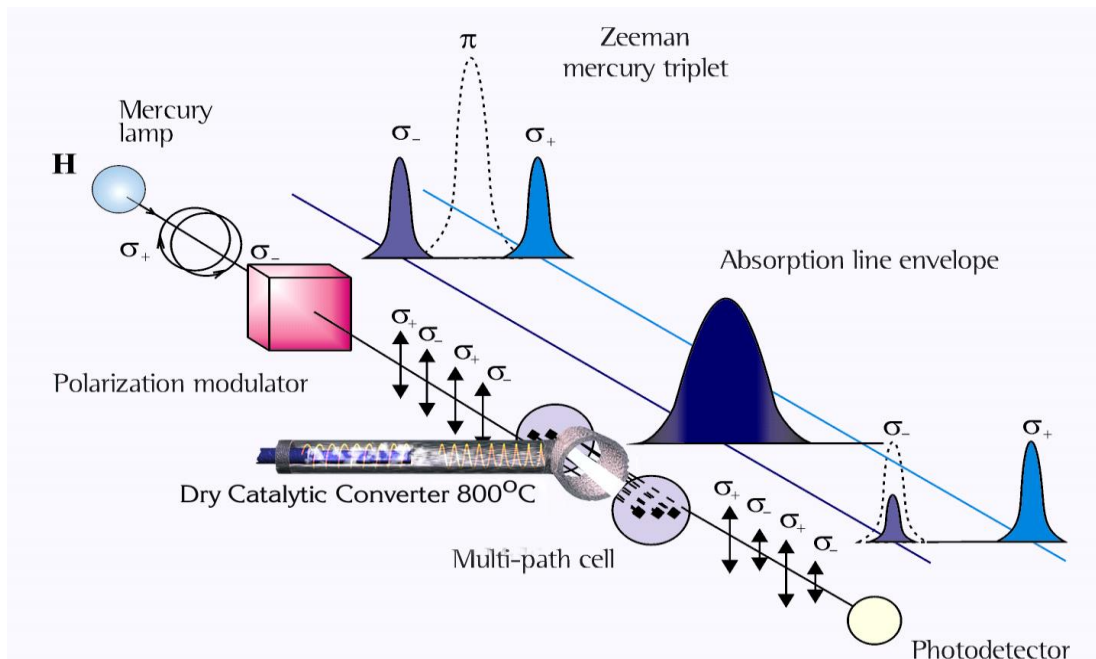

**Lumex-915M with RP-M324** is designed for field, on-site, and laboratory “Direct” testing of EPA PS-12B/Method 30B sorbent traps in accordance with the Mercury and Air Toxics Standards (MATS) rule. Analysis time is less than 2 minutes per sample and generates zero chemical waste. This analyzer may also be used for “Direct” testing of ash, coal, and “Ontario Hydro” method generated liquid samples.

A sorbent trap is cut and the sorbent media is transferred into a quartz ladle. The ladle is inserted into the analyzer’s thermo catalytic conversion chamber which is heated to 680°C. Mercury is then converted from a bound state to an unbound, atomic state by thermal decomposition.

This approach enables the operator to achieve analytical results of the highest quality in a short period of time. The use of a multipath cell combined with a “dry” converter provides the highest sensitivity with no interferences. Mercury measurements take place in the heated cell zone of the converter, directly coupled to a spectrometer. High temperature and short residence time prevents mercury atoms from recombining with

any “active” species generated due to high temperature decomposition of the sample matrix. An external pump with a mass flow controller draws ambient air into the catalytic chamber to aid in combustion and act as a carrier gas. No cylinders of oxidizer or compressed gases are required. No “clean” room is required.

### **TECHNICAL SPECIFICATIONS**

1. Detection limit: 0.5ng-100,000ng of mercury in sorbent, or 1 µg/kg - 1000mg/kg mercury concentration in coal or fly ash.
2. Precision: +-5%, Accuracy: +-5%.
3. Direct analysis (results in two minutes).
4. Calibration: Direct “spiking” of sorbent with Mercury NIST traceable Standard Referenced Materials.
5. Set-up or take-down time: less than one hour.
6. Utilities: 110v/60Hz, 1000Watt.
7. Dimensions and weight: Two Rolling Pelican Cases, 82 lb.

## Section 2: Getting Started

### 2.1: Setting Up

1. Make sure you have all the system components (see Picture 2.1). Note: components arrangement may slightly vary.



Picture 2.1 “RA-915M & RP-M324 in Pelican Shipping Cases”

2. In one of the two blue cases you will find the M324 Power Supply & Pump Module (see Picture 2.2).



Picture 2.2 “M324 Power Supply & Pump Module”

3. Another blue case contains the M324 Furnace & Spare Parts Kit (see picture 2.3).



Picture 2.3 "M324 Furnace & Spare Parts Kit"

4. Remove Furnace from Case (see Picture 2.4).



Picture 2.4

5. Clean Lens Before Attaching Furnace (see Picture 2.5).



**Picture 2.5**

6. Attach Furnace (rotate gently) to RA-915M (see Picture 2.6).

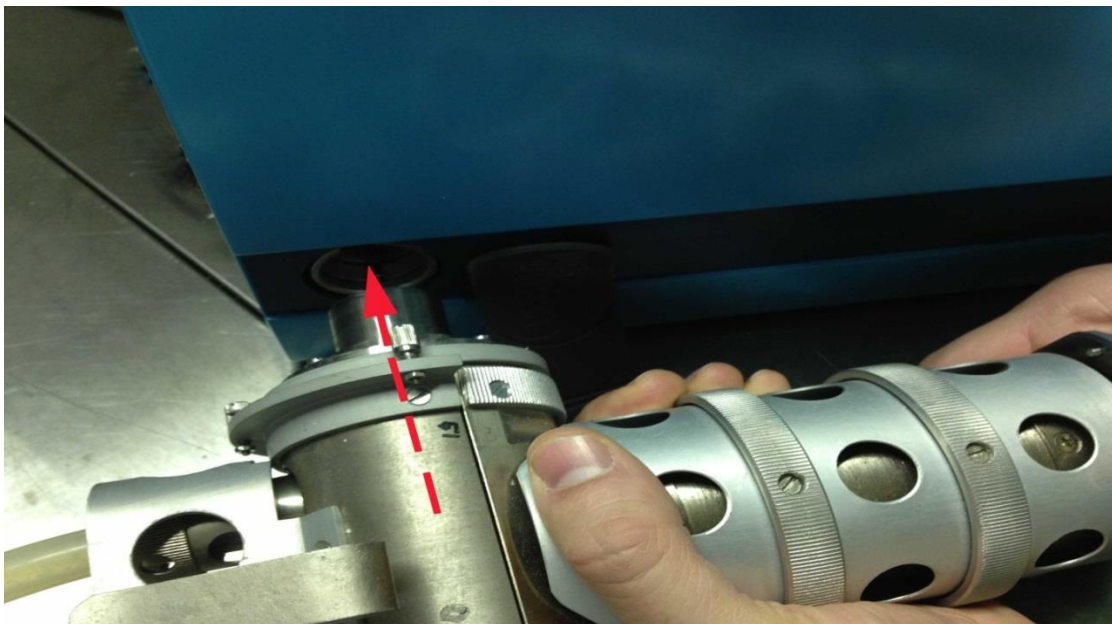

**Picture 2.6**

- Note Alignment Tabs: Make Sure Furnace alignment tab is against RA-915M tab stop (please clean the window) (see Picture 2.7).

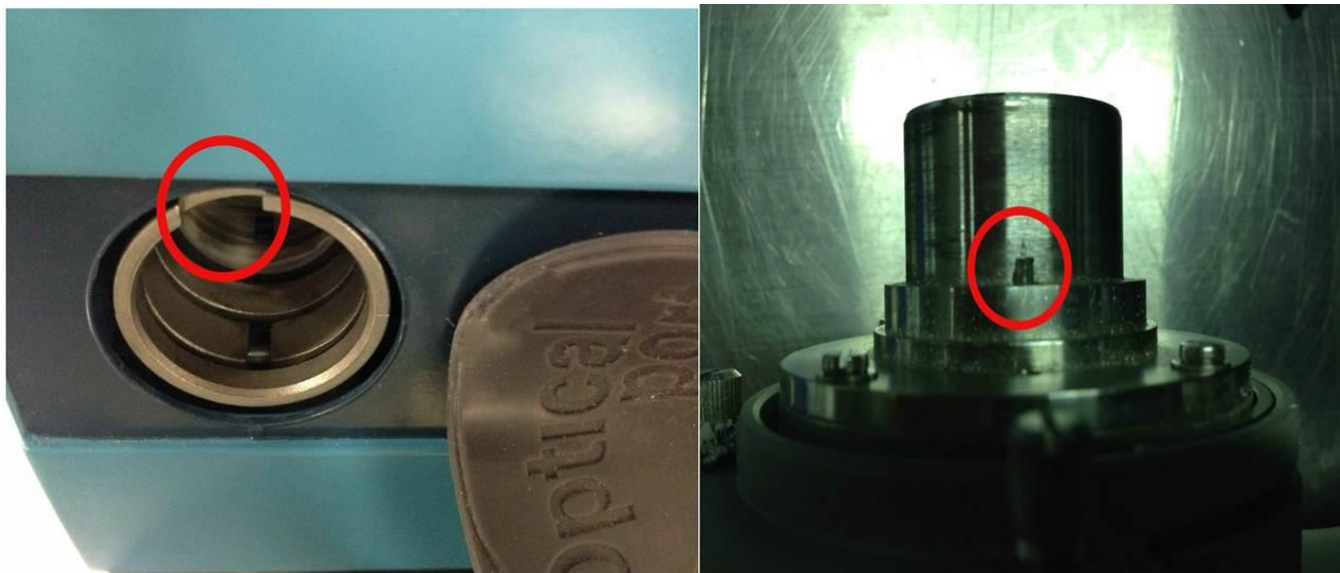

Picture 2.7

- Set up Gas Scrubber as pictured (see Picture 2.8): Acid scrubber (on the right) and carbon media (on the left) to catch Hg. Please make sure hoses and connections are not twisted or kinked. Important Leak Test: Pull hose and plug filter nozzle with a cap/finger. Observe flow meter reading slowly approaching zero.

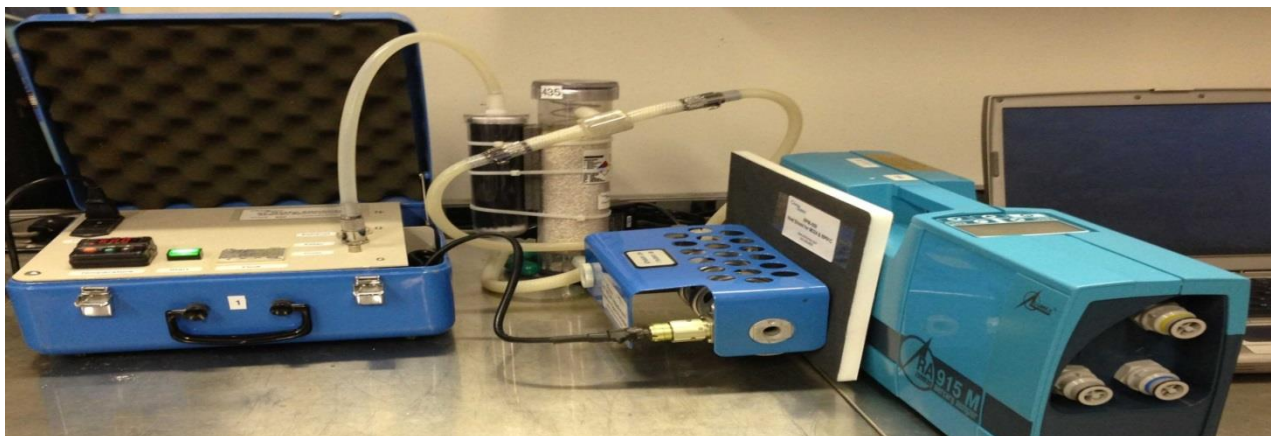

Picture 2.8

9. Tighten Screw with 2mm Allen wrench (Firm!!!, but don't over-tighten) (see Picture 2.9).

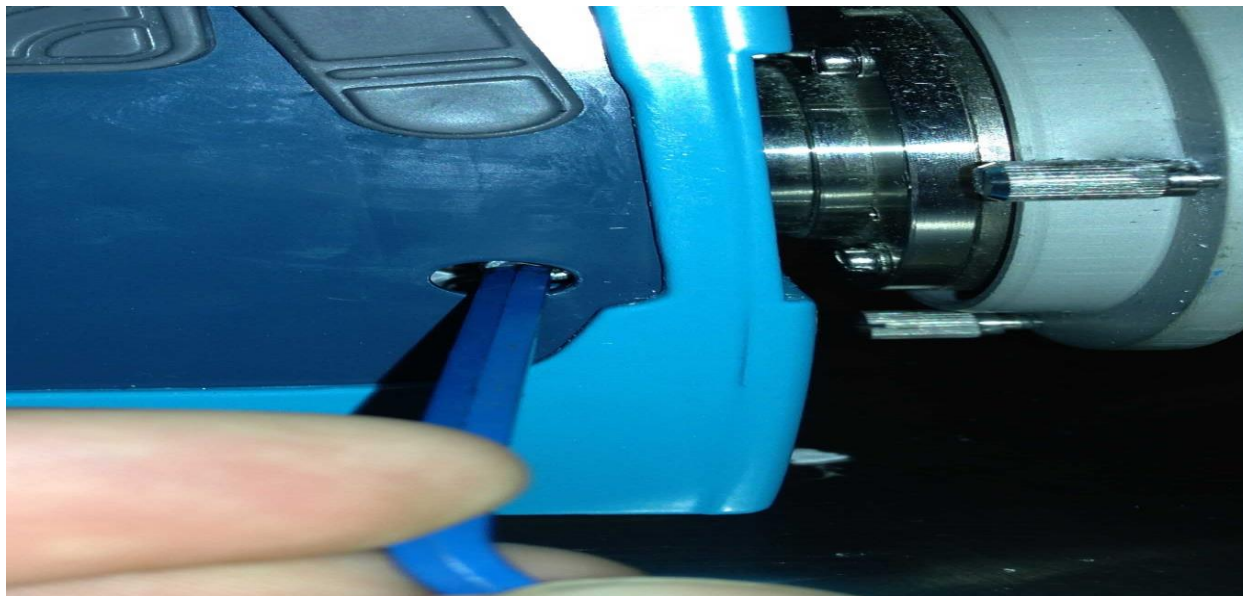

**Picture 2.9**

10. Attach USB Cable to USB 2.0 Type B Jack on RA-915M & to USB 2.0 Type A Jack on Laptop (see Picture 2.10). Warning: You must have your computer operational with Lumex software open before you make a connection. To the message: "No connection. Continue?" Click on Retry button.

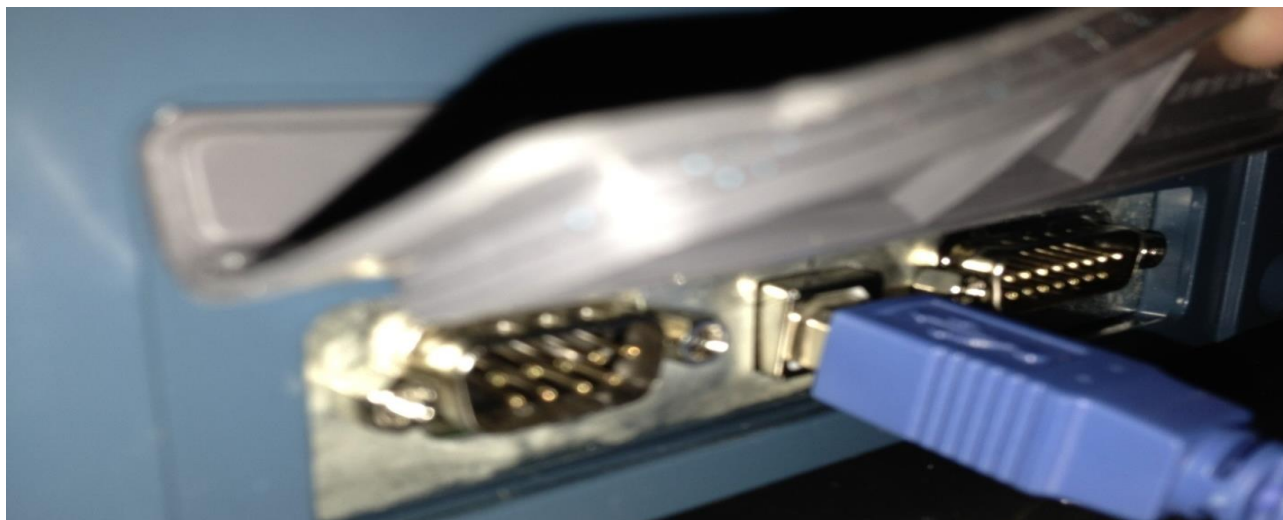

**Picture 2.10**

11. Connect Power Cord to back of RA-915M & Power on Analyzer (see Picture 2.11).



**Picture 2.11**

12. Open the Pump Module case (see Picture 2.12).

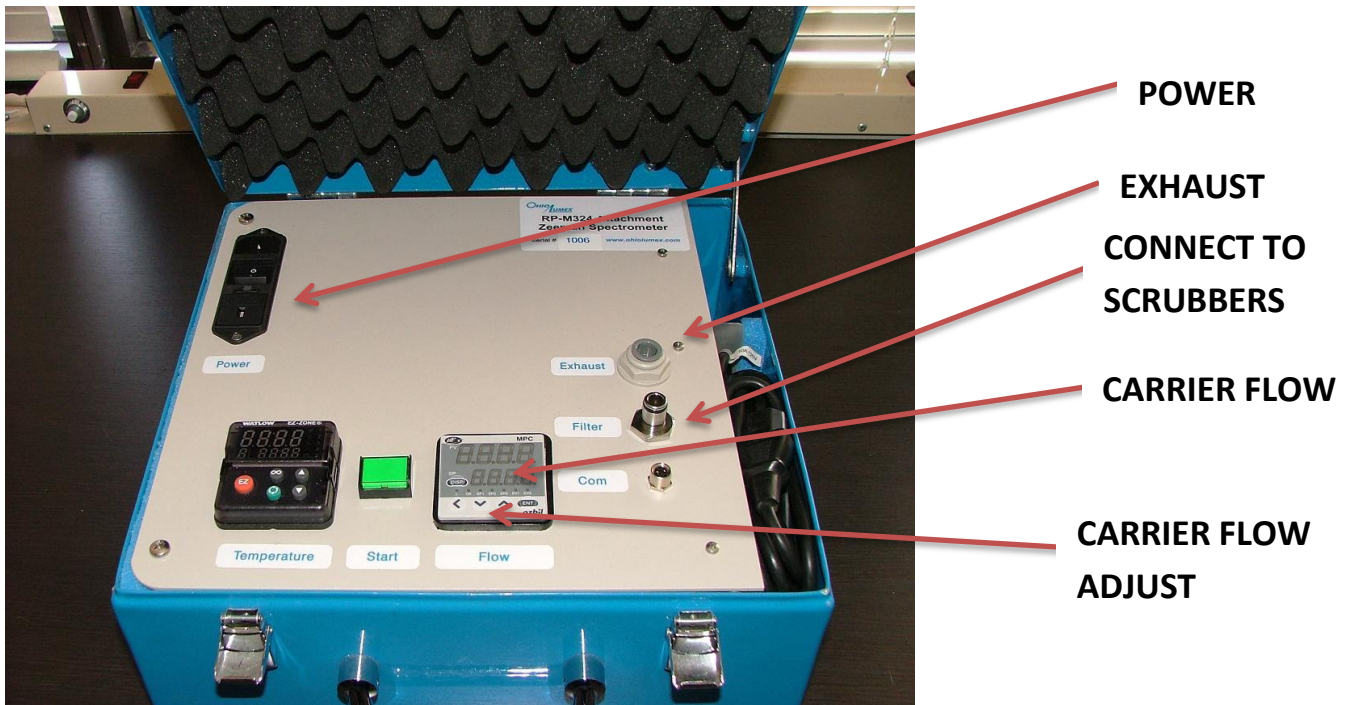

**Picture 2.12**

13. Align Red Dots & Attach Power Supply to Furnace (see Picture 2.13).



Picture 2.13

14. See below what the M-324M Workplace looks like (see Picture 2.14).

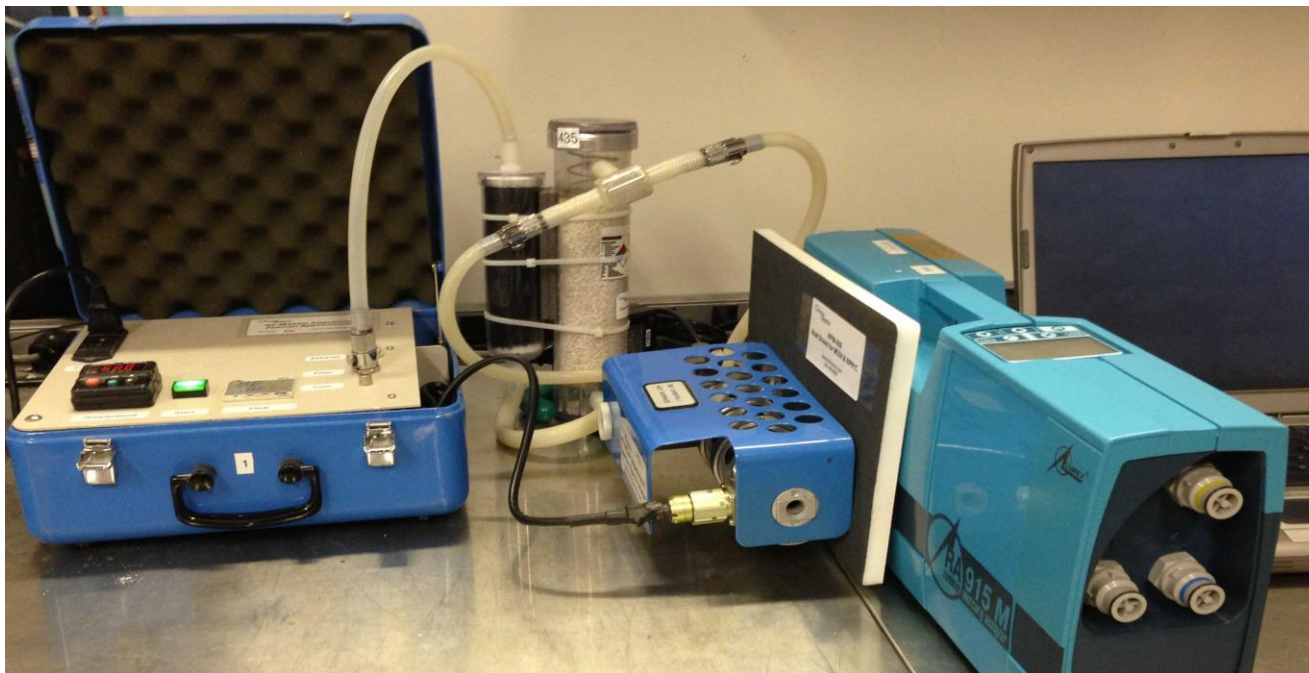

Picture 2.14

15. To start the pump Press Power Button on Power Supply (see Picture 2.15).



Picture 2.15

16. Complete Setup with Heat Shield (see Picture 2.16).



Picture 2.16

17. Turn Power ON, select Profile 1 on the Watlow EZ-Zone controller (see Picture 2.17), and allow Furnace to Heat up for 45 minutes with pump ON. Green number is a Set Temperature and Red number is Furnace Temperature.



Picture 2.17

## 2.2: Selecting and Running Temperature Profiles with EZ-ZONE RP-M324 controller

### Start up and Profile selection

**Denotations:** InfK - Black infinity key, AdvK - green advance key.

1. Turn Power ON, warm up furnace at 680°C for approximately 45 min with pump ON.
2. Press **AdvK**, Select profile 1, 2, 3, or 4 by pressing **Up or Down Arrow Keys**.
3. Press **AdvK** and select **Prof** by cycling **Up or Down Arrow Keys**. Press **InfK** to save selection and exit.
4. Wait for Green Ready Light to come on before starting profiles 3, 4 (Profiles 1 and 2 = Light is always ON).

### Change Profile (profile must be ended before the new one is loaded)

1. Press **AdvK** and using **Up or Down Arrow keys** select **END**. Press **InfK** to enter.
2. Reset controller by cycling the power button on the back of controller.

**Table 2.1 Profiles**

	Temperature, °C	Flow, LPM	Technique	Range, ng
Profile 1 (P1)	680	0.5/2	Light is ON. Insert ladle at any time, not ramping	2 – 300/10-2,000
Profile 2 (P2)	652	4	Light is ON. Insert ladle at any time, not ramping	10-4,000
Profile 3 (P3)*	653	4	Wait for light, push to start. Ramping	5,000 – 10,000
Profile 4 (P4)*	654	4	Wait for light, push to start. Ramping	10,000 – 30,000

\*Note: Because a single sample run in P3 & P4 requires a substantial amount of time, it's more beneficial to break up a sample section (for example, 20,000 ng spike) over multiple ladles and analyze in P1 or P2.

### **Ranges**

Profile 1: up to 0.5-2 hours sampling (RATA) Testing takes 2 minutes

Profile 2: up to 7 days sampling (wet scrubber), Testing takes 2 minutes

Profile 3: up to 5 days sampling (no scrubber), Testing takes 6 minutes

Profile 4: up to 7 days sampling (no scrubber), Testing takes 10 minutes

### **Temperatures and air flow**

Profile 1: Temp. 680°C, Isothermal. Flow 0.5/2 LPM

Profile 2: Temp. 652°C, Isothermal. Flow 4 LPM

Profile 3: start at Temp. 653°C, Ramping. Flow 4 LPM

Profile 4: start at Temp. 654°C, Ramping. Flow 4 LPM

## Actuating a profile sequence

Press **AdvK**, Select File 1, 2, 3, or 4 by pressing **Up, Down Arrow Key**. Press **AdvK** to select **PROF** and press **InfK**. To start Sample Run, Press Green Start Button (only for Profile 3-4).

1. Press AdvK Select File use Up/Down Arrows

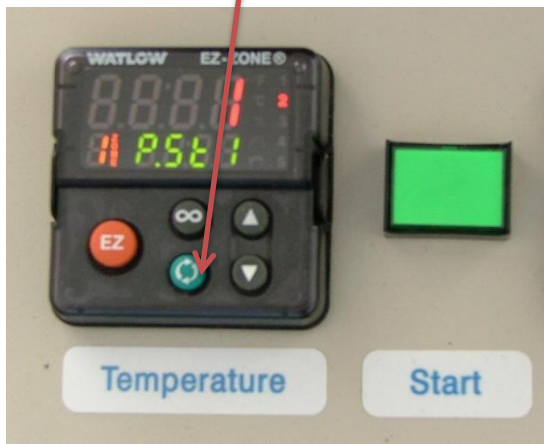

2. Press AdvK Select Action: PROFILE and press InfK to exit to home screen

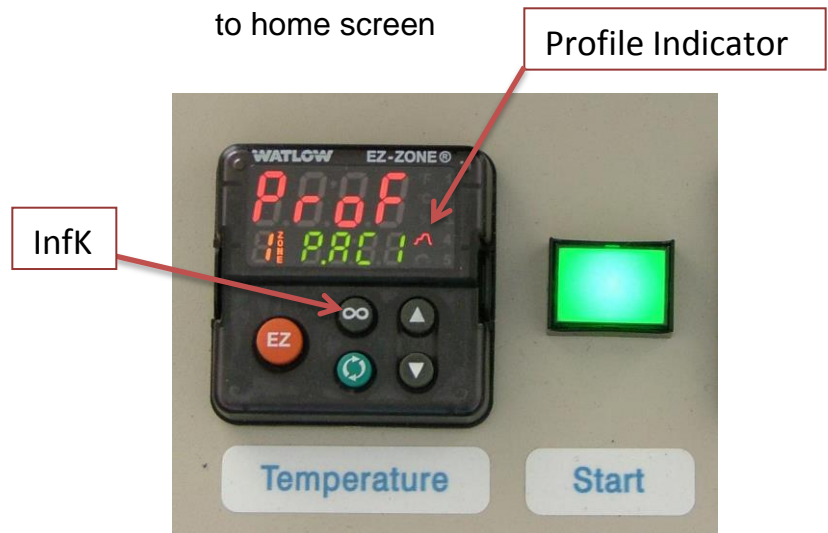

3. When it comes time to run a sample, press the Green Start Button before placing the ladle in the furnace (only for Profile 3-4).

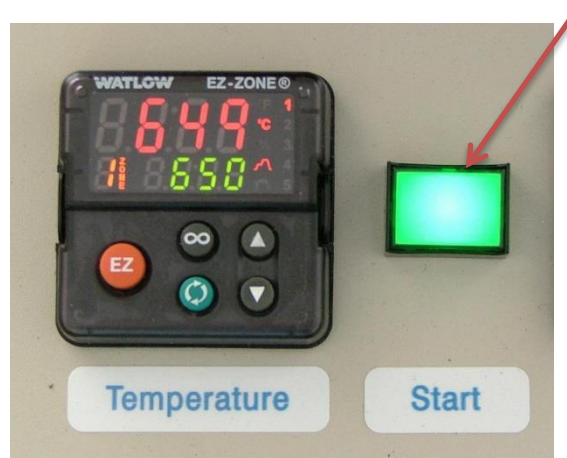

## Section 3: Launching RAPID Software

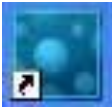
1. Open RAPID Software by clicking the  icon located on your desktop.
2. On the pop-up menu, click & open “Instrument information” (Picture 3.1).



Picture 3.1

3. Select & connect to the appropriate analyzer then click Exit (Picture 3.2).

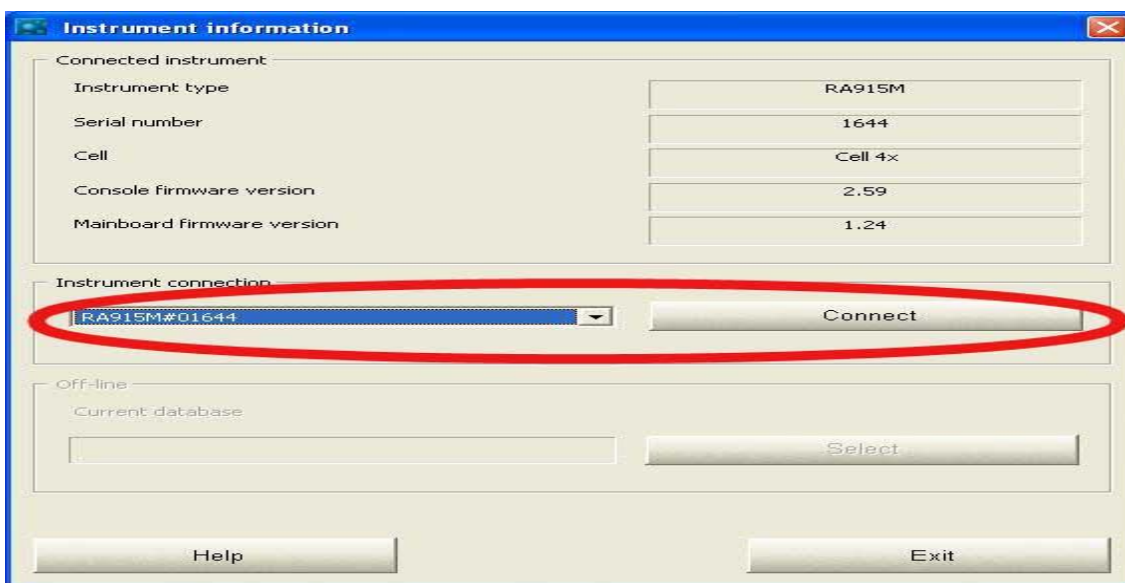

Picture 3.2

- Click & open Sample Analysis (Picture 3.3).

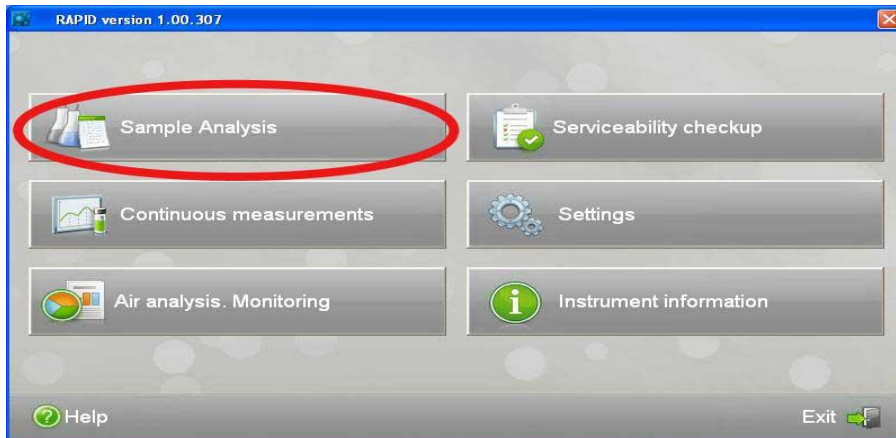

Picture 3.3

- Once the chart/graph are open, configure the “view settings” as seen below by clicking the  icon. Click Apply when finished.

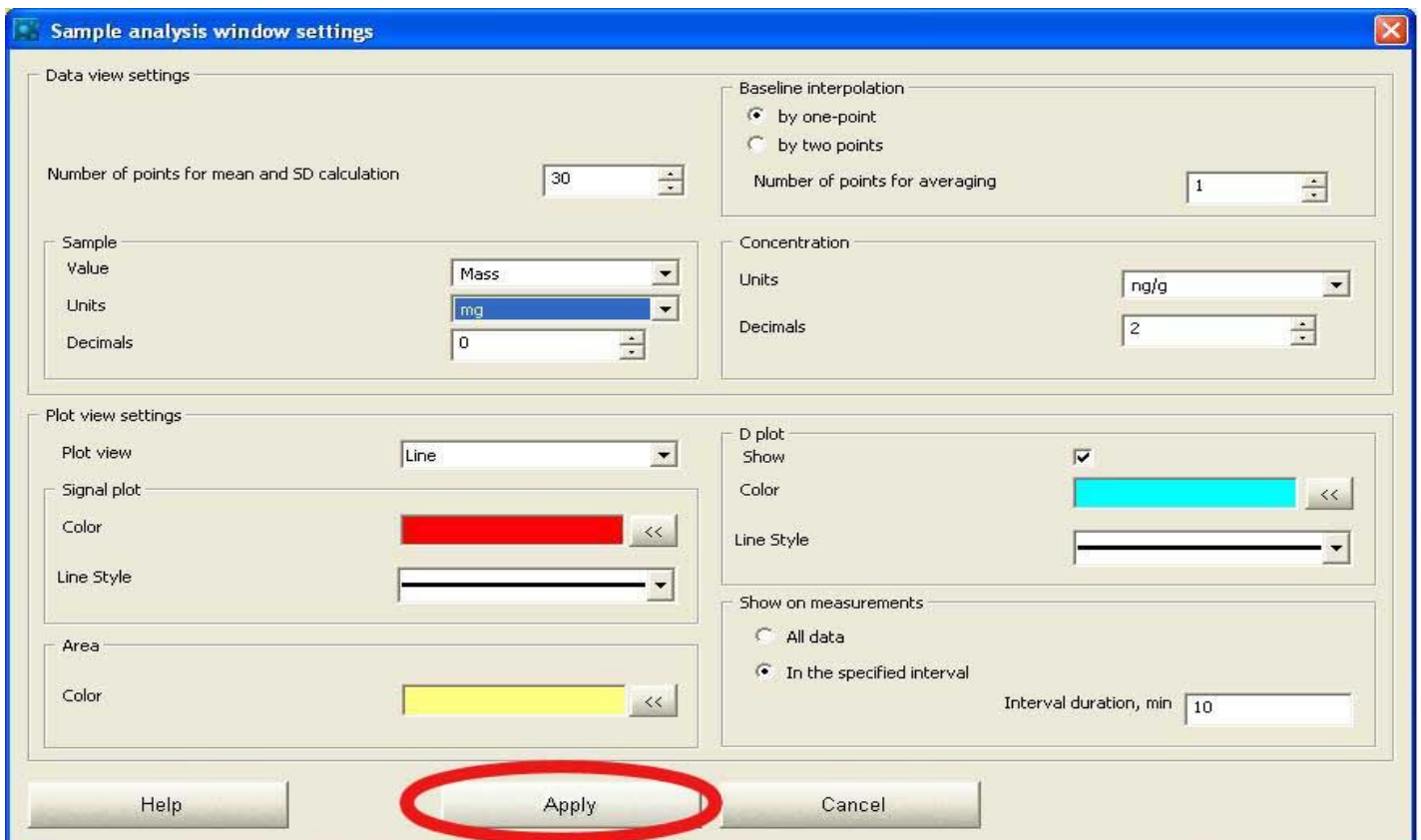

Picture 3.4



## Section 4: Multi-Point Calibration & Ladle Technique

### 4.1: Manual Integration Calibration Method

1. Allow RA-915M/M-324 System to warm-up for at least 45 minutes.
2. Fill in “Sample description,” “ref. data,” & “Mass/Volume” (Picture 4.1).
  - *Note: The example used below assumes an initial calibration point of 10 nanograms. Yours may be different depending on sample parameters*
  - *Note: “ref. data” refers to the expected mass of the Standard being used.*
  - *Note: When analyzing sorbent traps, the “Mass/Volume” will ALWAYS be “1”.*

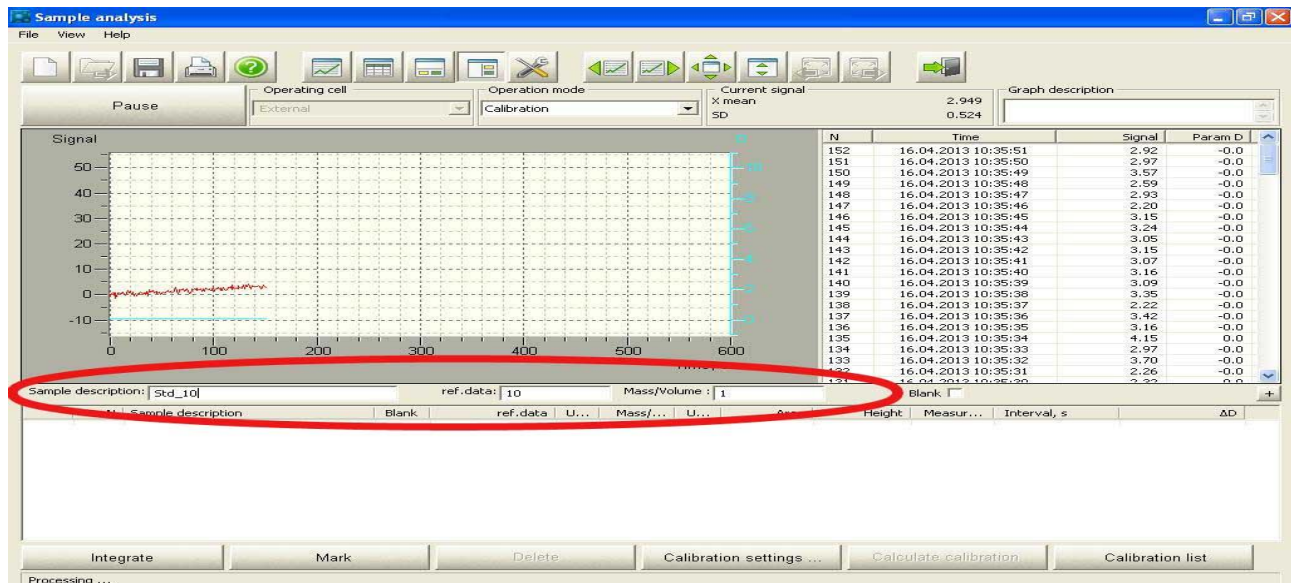

Picture 4.1

3. Prepare your first Hg Standard & place it inside the atomizer chamber. (A detailed explanation on how to properly prepare Hg Standards can be found pages 45-49). *Note: With older versions of the software it is necessary to click a START and END button; however, the Manual Integration Method herein DOES NOT require this function.*

- Remove the Standard sample from the atomizer once the Hg has been read by the analyzer.

*Note: The Hg is fully desorbed from the sample AFTER the peak returns to baseline.*

*Note: The Signal Column indicates the baseline/peak (Picture 4.2).*

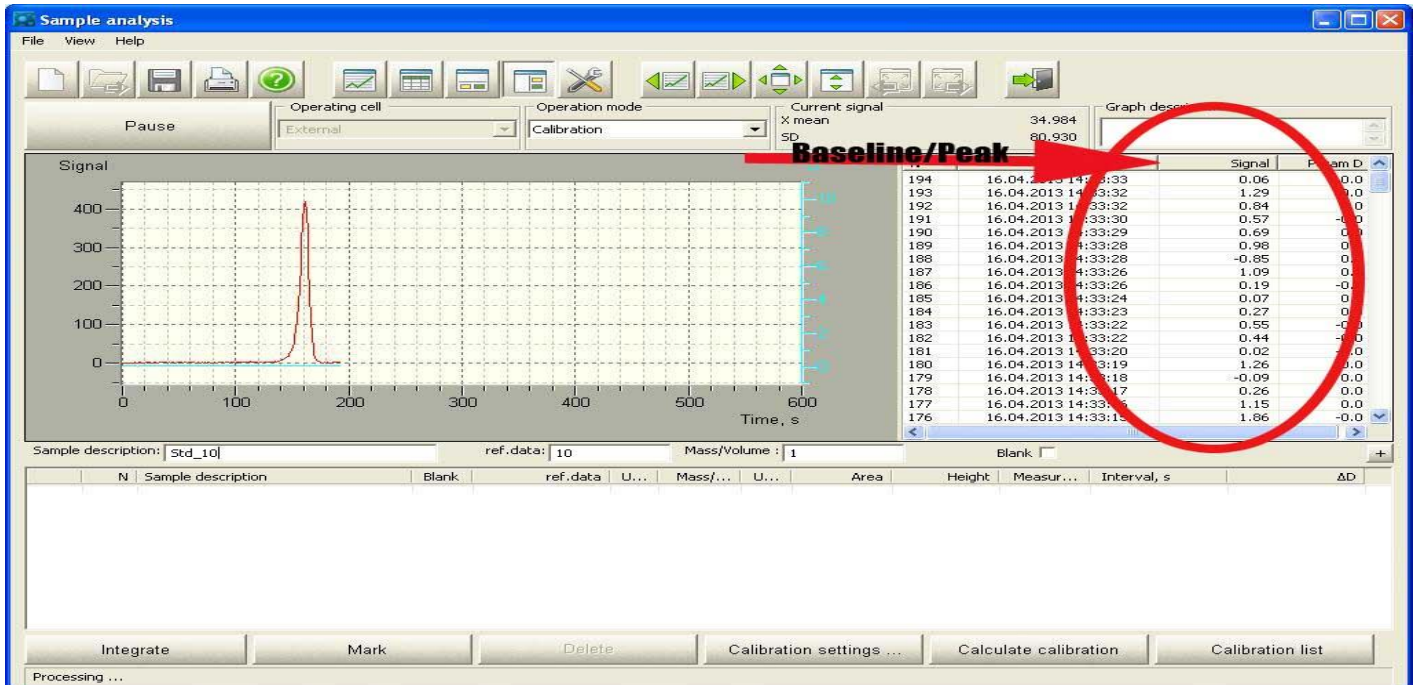

**Picture 4.2**

- Create a zoom box by clicking and dragging your cursor over the peak ensuring only the beginning and end of it lie within the zoom box.
- Click "Integrate" (Picture 4.3).
  - Note: The baseline signal will continue to count even when zoomed in.*
  - Note: You may zoom in (multiple times if necessary) till you feel confident with your zoom box.*

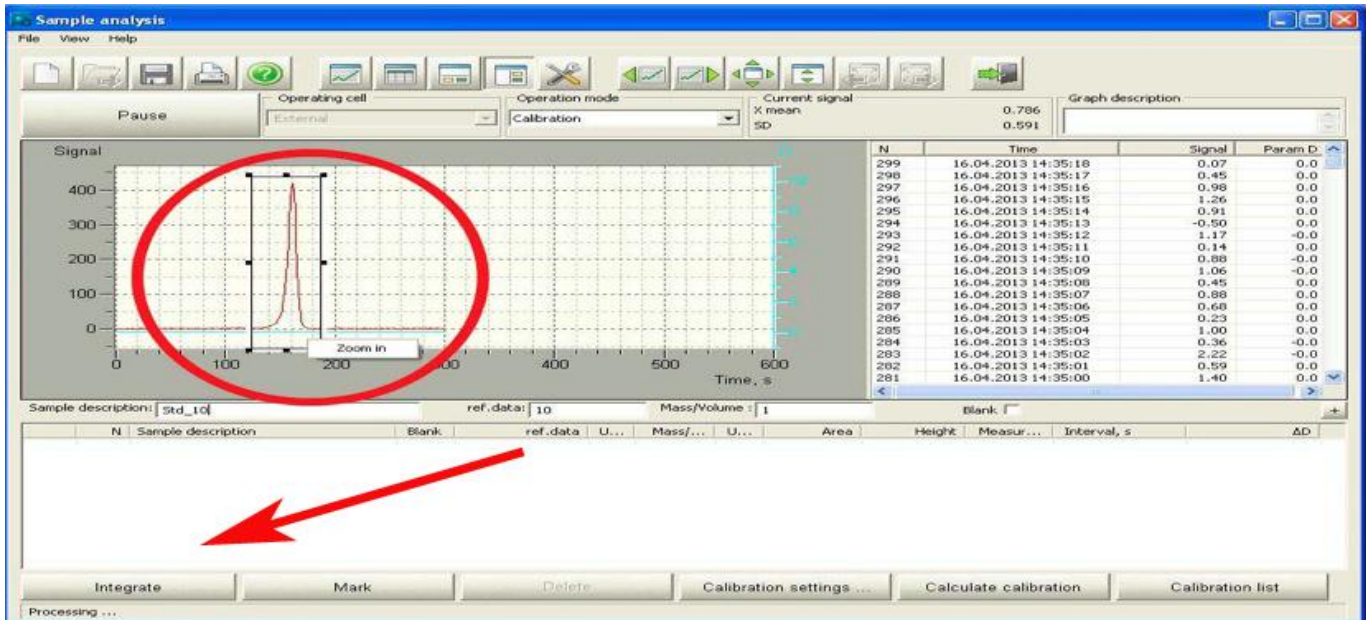

Picture 4.3

7. Repeat steps 2 thru 6 till you've ran at least three Standards.

8. Mark the check box next to each Standard you want used in your calibration & click "Calculate calibration" (Picture 4.4).

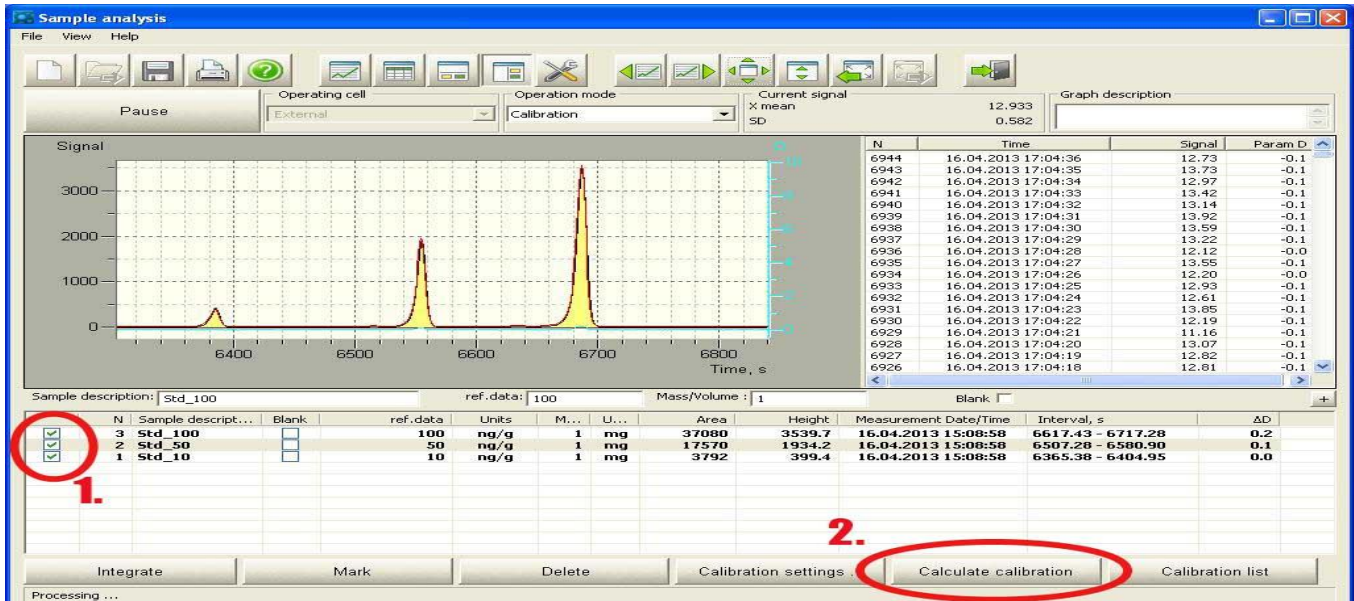

Picture 4.4

9. Under “Data view” click “Table view” & use the scroll bar to locate the “Calculated, ng/g” mass per each Standard used in the calibration.
10. Once satisfied, name your calibration and click “Save” (Picture 4.5).

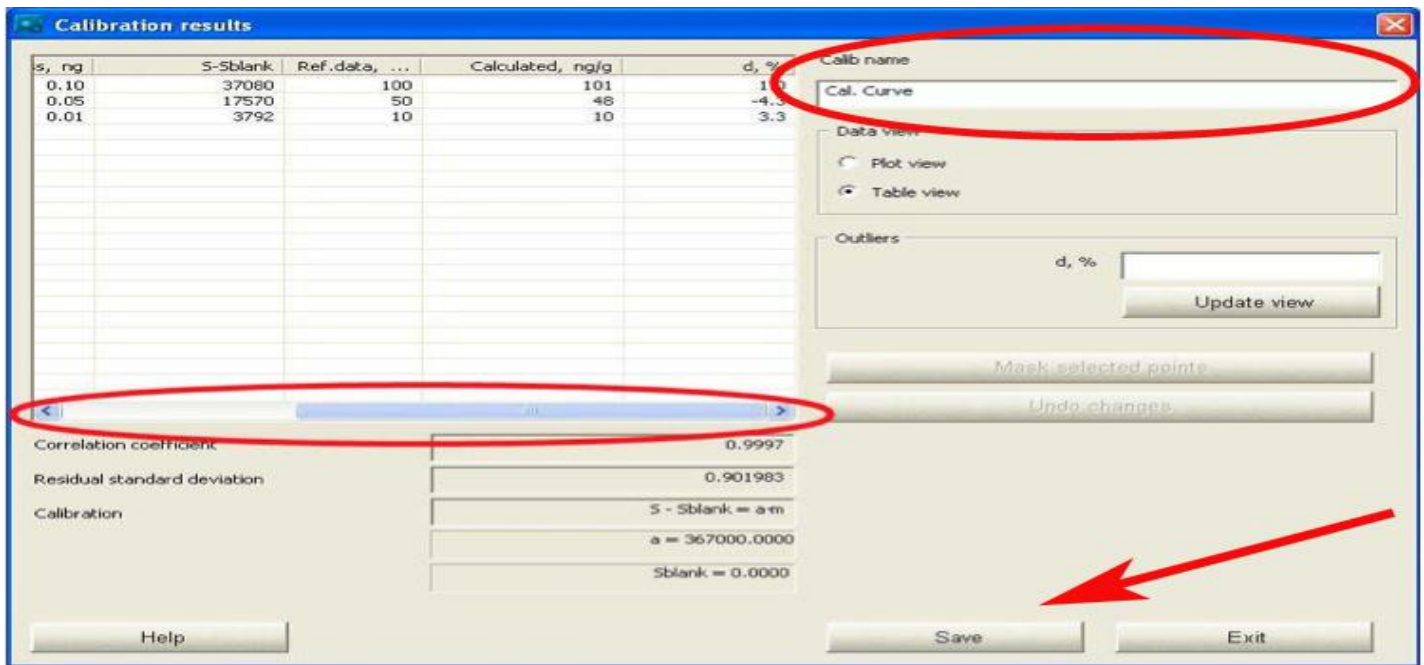

Picture 4.5

## 4.2: Mark & Integrate Calibration Method

- 1) Allow RA-915M/M-324 System to warm-up for at least 45 minutes.
- 2) Fill in “Sample description,” “ref. data,” & “Mass/Volume” (Picture 4.6).
  - Note: The example used below assumes an initial calibration point of 10 nanograms. Yours may be different depending on sample parameters.
  - Note: “ref. data” refers to the expected mass of the Standard being used.
  - Note: When analyzing sorberent traps, the “Mass/Volume” will ALWAYS be “1.”

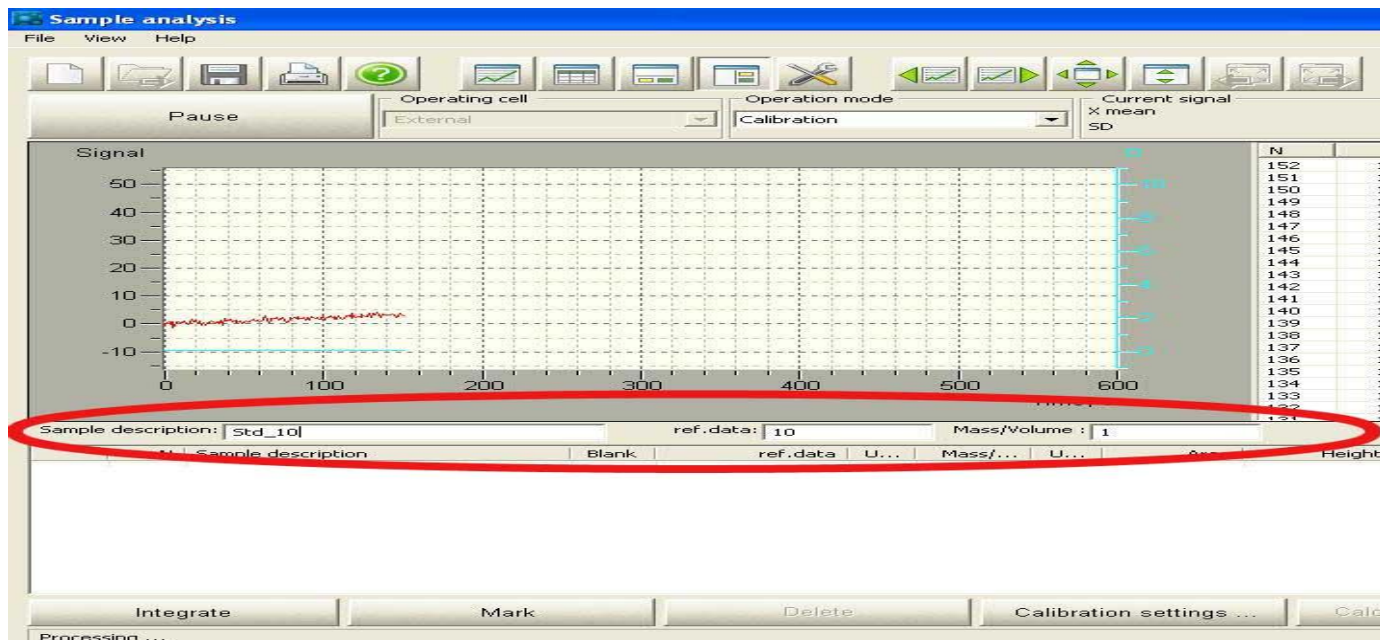

Picture 4.6

3) Prepare first Hg Standard (as outline on pages 45 – 49), click “Mark” then place the ladle inside atomizer chamber (Picture 4.7).

a. Note: The “Mark” button will change to “Mark and Integrate” once clicked.

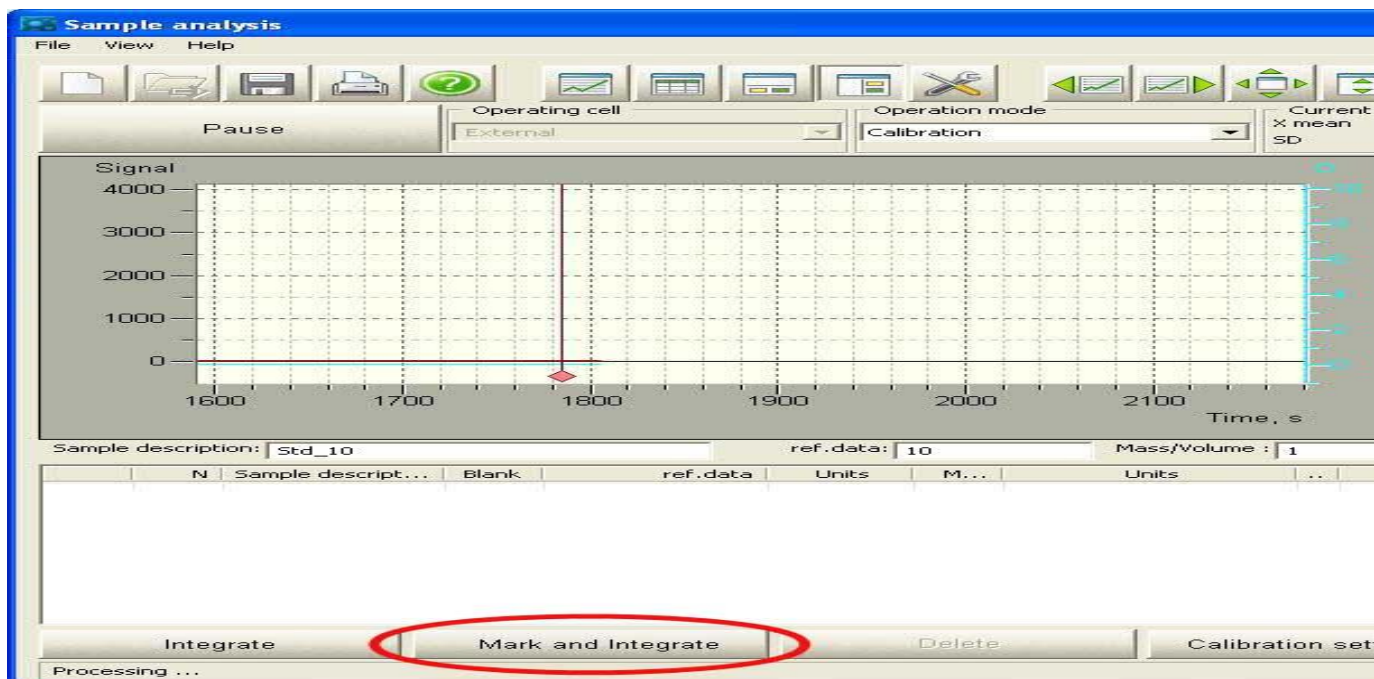

Picture 4.7

- 4) Once the peak has returned to baseline, click “Mark and Integrate” to finish the run.
  - a. Note: The “Mark and Integrate” button will revert back to “Mark” once clicked (Picture 4.8).

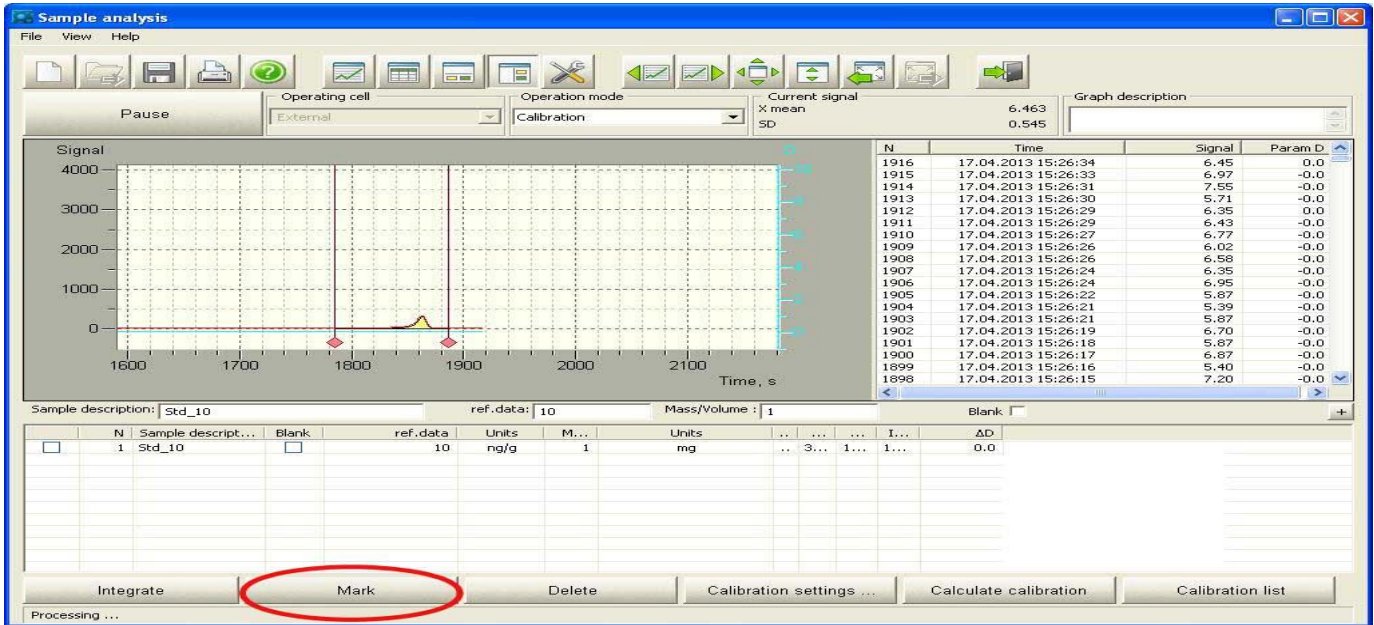

Picture 4.8

5. Repeat steps 2 thru 4 till you’ve ran at least three Hg standards.
6. Mark the check box next to each Standard you want used in your calibration & click “Calculate calibration” (Picture 4.9).

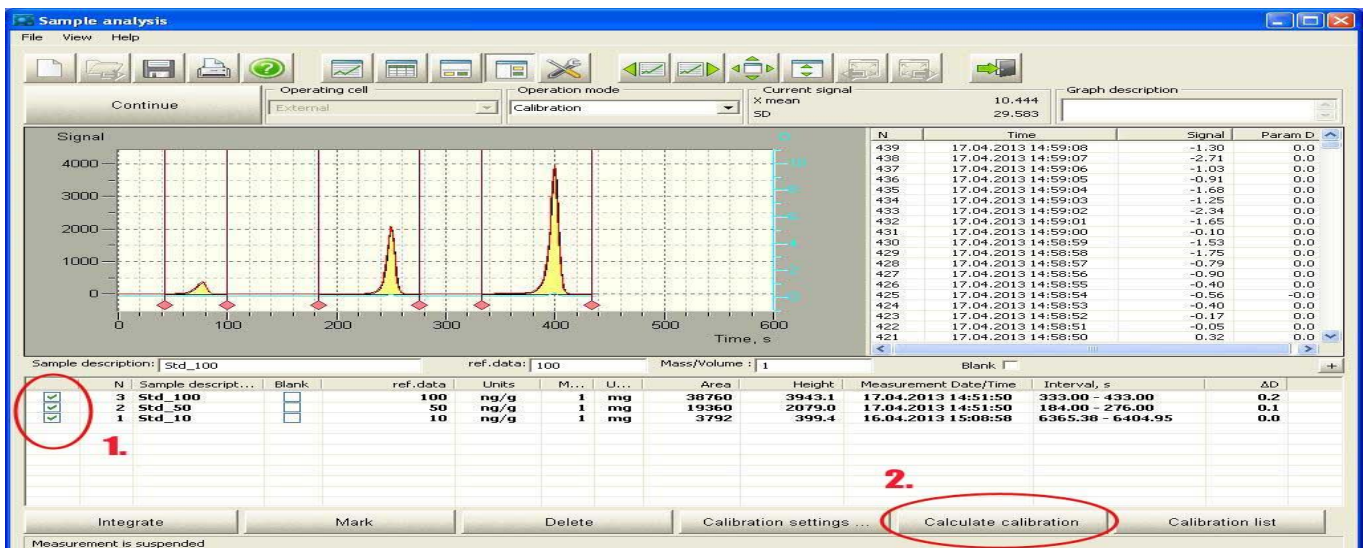

Picture 4.9

- Under "Data view" click "Table view" & use the scroll bar to locate the "Calculated, ng/g" mass per each Standard used in the calibration.
- Once satisfied, name your calibration and click "Save" (Picture 4.10).

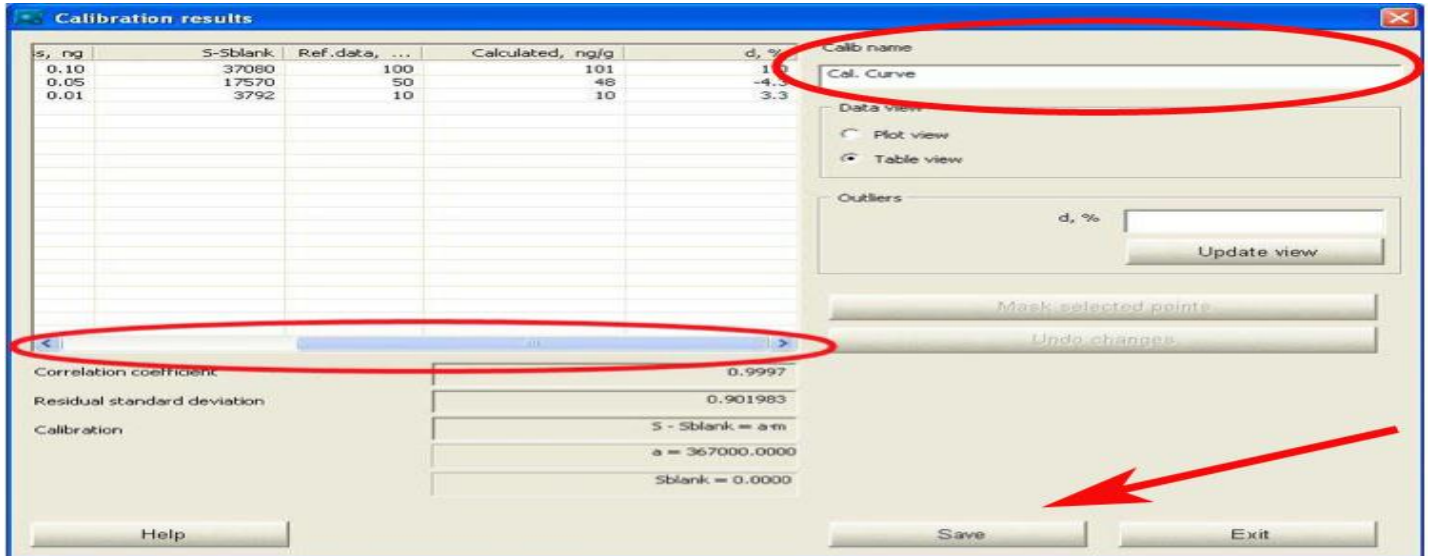

Picture 4.10

### 4.3: Analyzing Sorbent Trap Samples

1. Select “Analysis” from the “Operation mode” drop down menu.
2. Choose your just completed calibration by clicking the “Choose calibration” button (Picture 4.11).

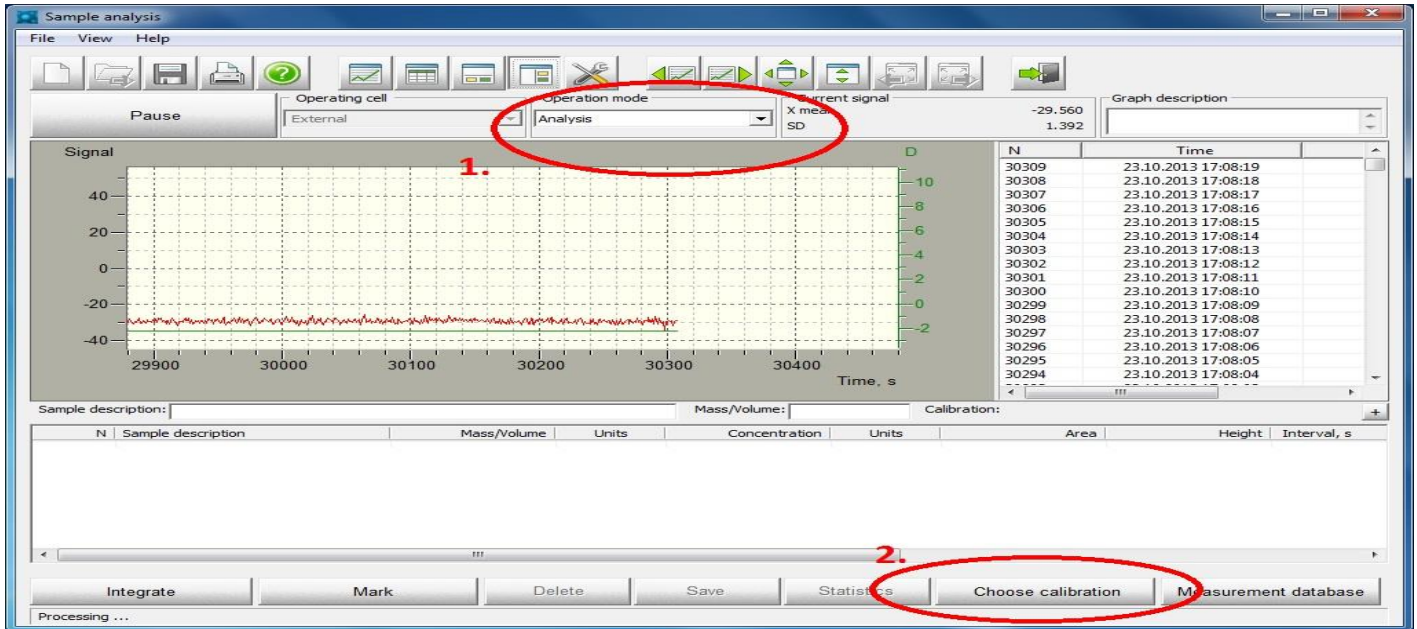

Picture 4.11

3. Select the proper calibration curve to apply to the forthcoming sorbent trap samples from the drop down menu then click “Apply” (Picture 4.12).

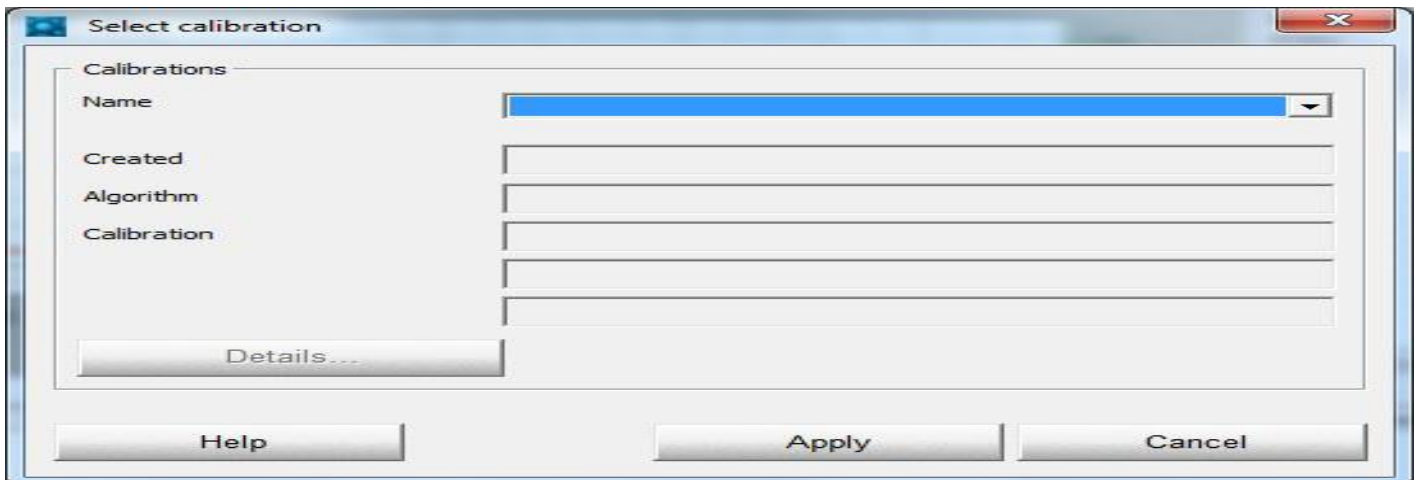

Picture 4.12

4. Prepare sorbent trap sample according to pages 48 to 53 and follow the Manual Integration Method or Mark & Integrate Method to analyze your sample (Picture 4.13).



Picture 4.13

5. Saving you data. When it comes time to save your data, press the “Save” button and label your graph under “Graph description.” A save disk icon will appear next to all saved runs. **PROGRAM DOES NOT SAVE AUTOMATICALLY**, so be sure to save data early and often (Picture 4.14).

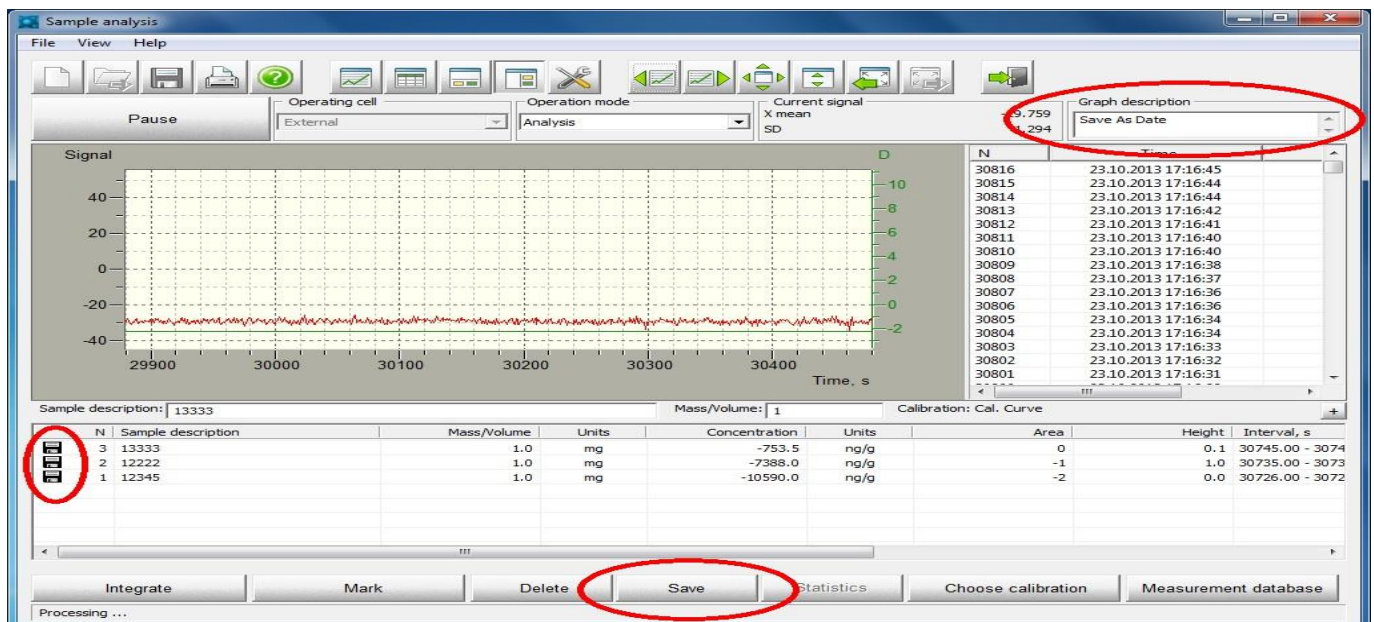

Picture 4.14

- Retrieving your data. To access your saved data, press the “Measurement database” button and choose how you’d like to export your data (Pictures 4.15 and 4.16).

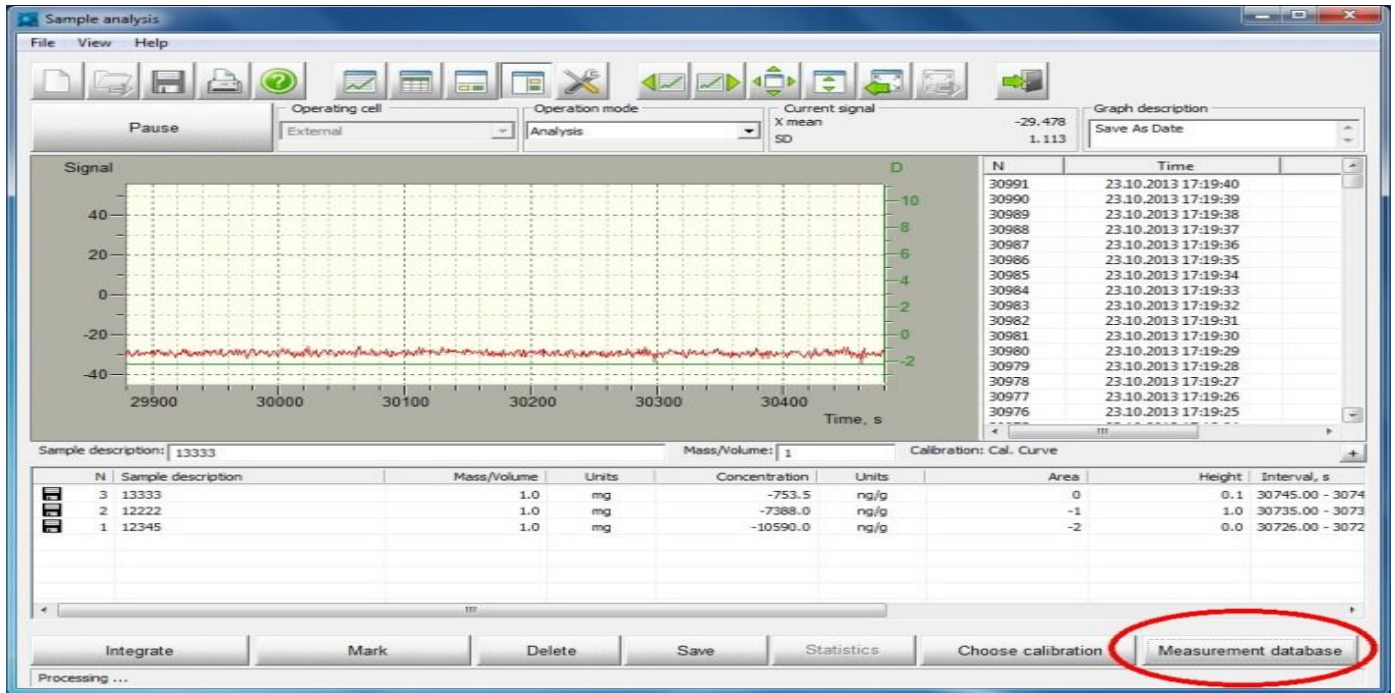

Picture 4.15

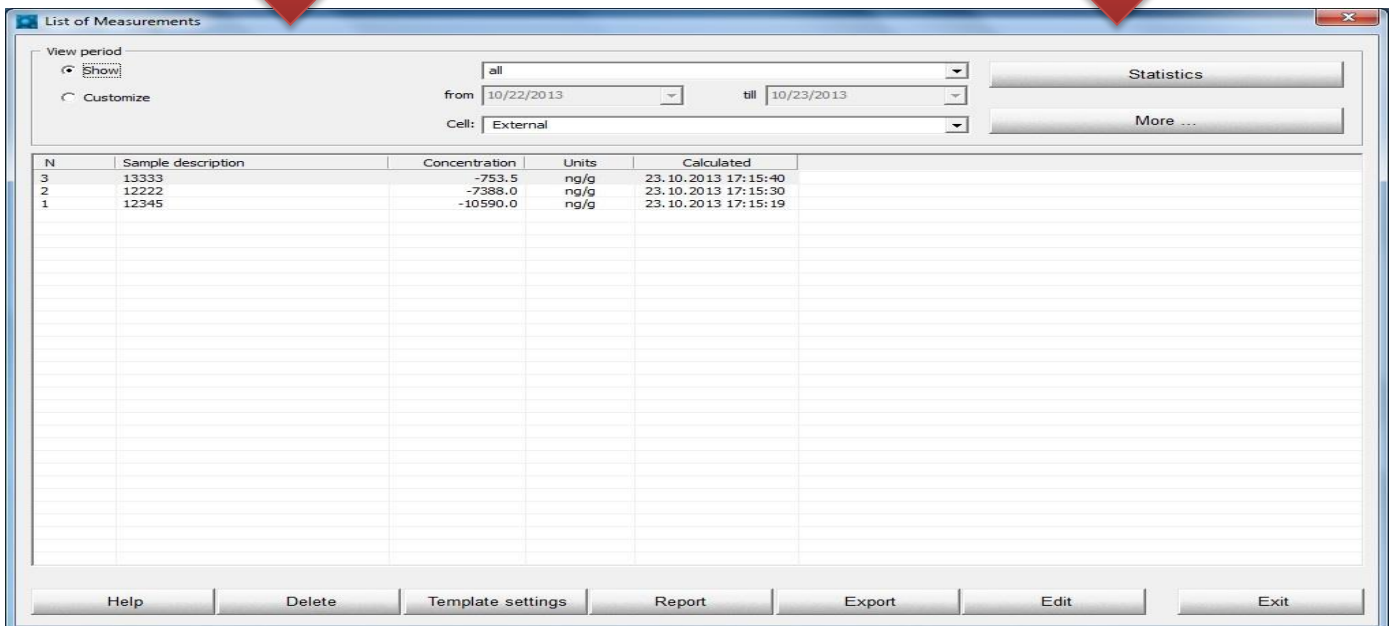

Picture 4.16

## Section 5: Ladle Preparation

1. Universal (for 6mm and 10 mm length traps) Ladle for Sorbent Trap testing placed on folded, 8.5 x 11 inch printer paper.



Picture 5.1

2. **For calibration** with NIST traceable Mercury standard pour calibration sorbent (carbon) in ladle, position pipette above sorbent distributing drops in one (middle) point on top of the carbon. Do not use pipettes capacities less than 20 or larger than 50 micro-liters for “small-6mm” traps and 20-100 micro-liters for “large-10mm” traps.

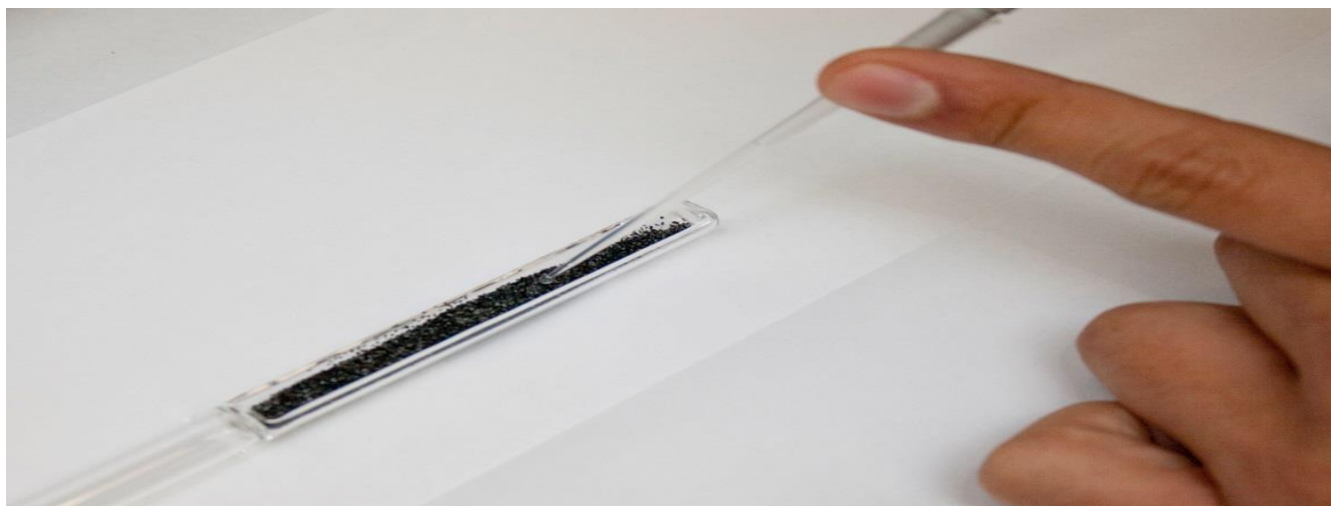

Picture 5.2

3. Sprinkle "soda" (Sodium Carbonate) on top of the spiked sorbent covering it completely (Picture 5.3).



Picture 5.3

4. Brush off excessive soda (Picture 5.4) then cover loaded ladle with fresh foil and apply slight finger pressure to press/pack down the sample (Picture 5.5). Do not reuse foil. Wipe the edges of the ladle and the bottom clean from soda grains (Picture 5.6). Be careful not to spill soda in the oven.

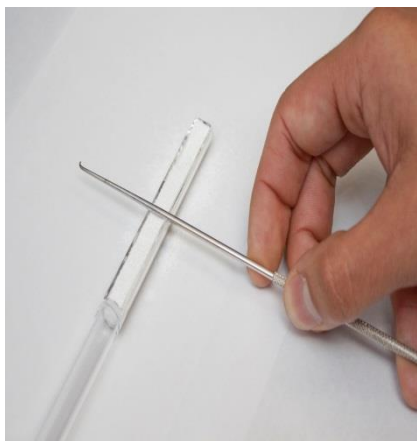

Picture 5.4



Picture 5.5



Picture 5.6

5. Slowly (**not to spill soda**) insert Ladle with gold dot facing up and seat completely inside furnace (Picture 5.7). After removal, place ladle on foil to cool and use narrow metal spatula to empty. The ladle comes out of the furnace **“mercury free” and is ready to be reused.**



Picture 5.7

## Section 6: Sample Preparation

1. Use a Dremel tool with a diamond disk to cut trap (Picture 6.1) and break glass open just above the first plug and remove the plug with a glass wool extractor (Picture 6.2).

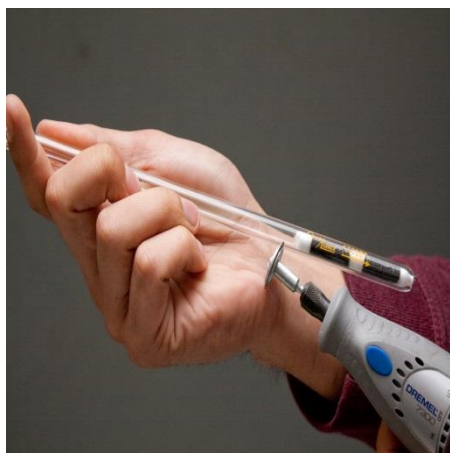

Picture 6.1

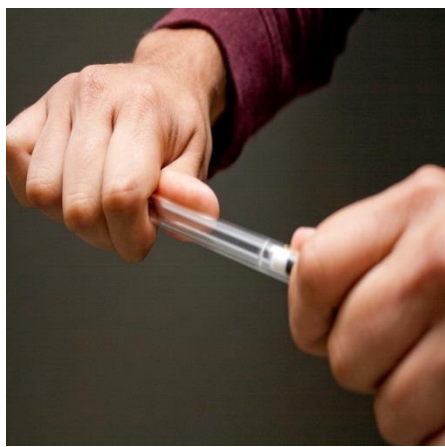

Picture 6.2



Picture 6.3

2. **Use gloves when handling sorbent traps.** Carefully remove the glass wool plug (Picture 6.4) and discharge sorbent on a fresh 8.5 x 11 inch piece of printer paper folded in half (Picture 6.5).

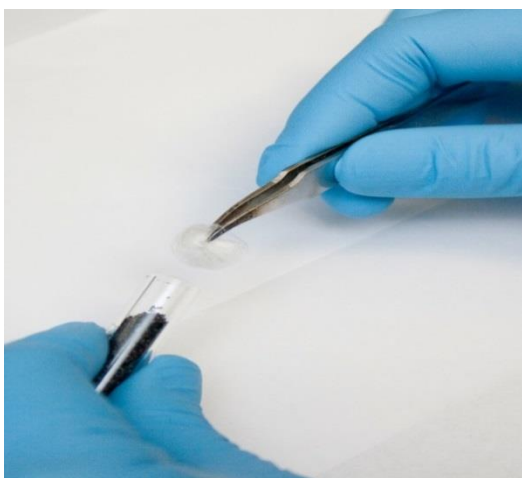

Picture 6.4



Picture 6.5

3. Roll up the glass wool plug in a small piece of aluminum foil (Picture 6.6). Be sure no glass wool is exposed (Picture 6.7).



**Picture 6.6**

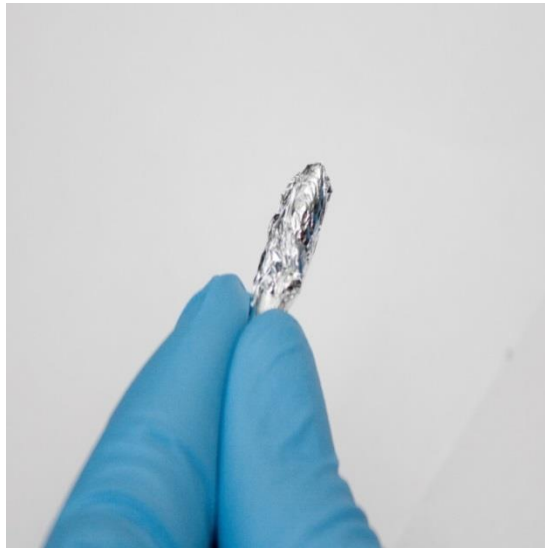

**Picture 6.7**

4. Place the plug in the ladle along with the carbon. A second piece of folded 8.5 x 11 inch printer paper should be placed under the ladle to catch any spilled carbon (Picture 6.9).

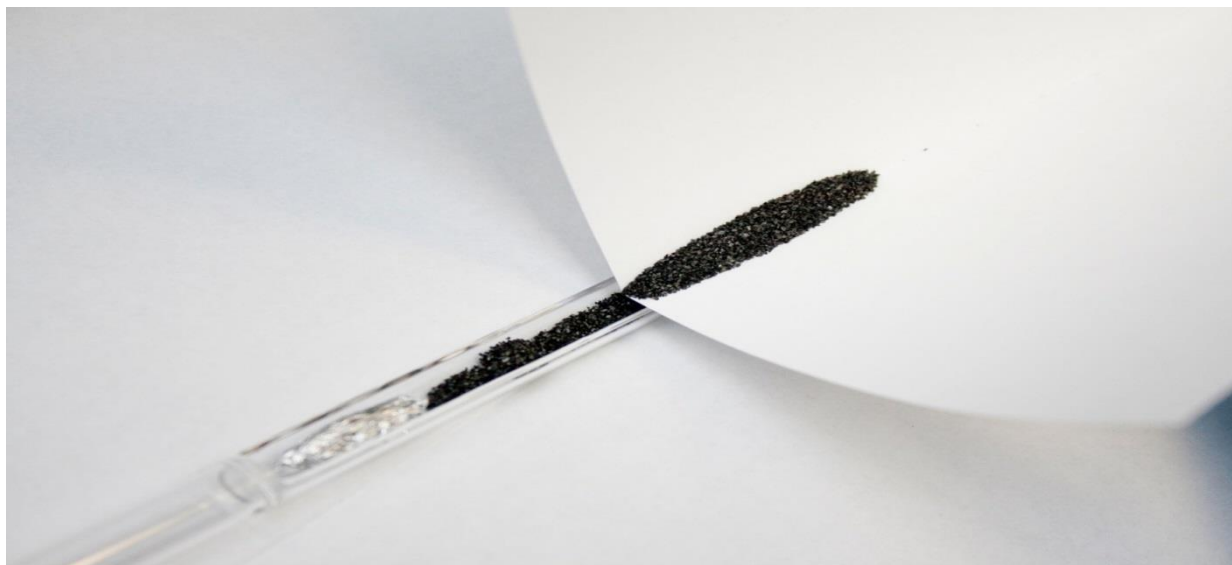

**Picture 6.9**

5. Sprinkle sodium carbonate (soda) on top ensuring no carbon is exposed. Wipe away any excess soda with glass wool extractor or spatula tool.

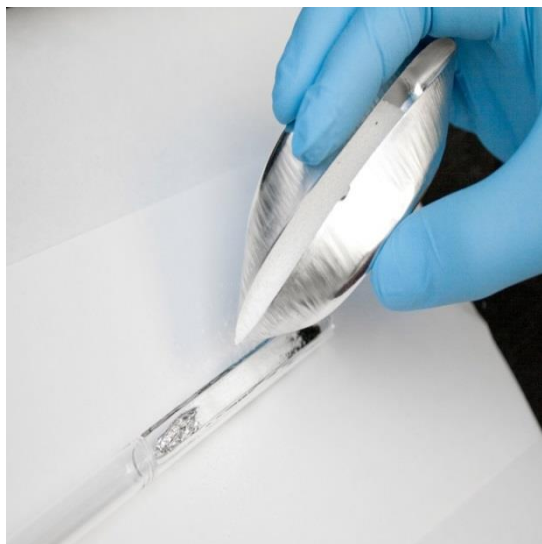

**Picture 6.10**



**Picture 6.11**

6. Again, cover loaded ladle with fresh foil and apply slight finger pressure to press/pack down the sample. The picture below shows a properly prepared sample ready for analysis.



**Picture 6.12**

## Section 7: Maintenance

- 1. Cleaning lenses.** Cleaning of the lenses is required when RSD value in Graph window exceeds 5 or 10 units. The reading represents baseline noise RSD and must be observed at the beginning of testing (after warm up period) or between samples when baseline stabilizes.



Picture 7.1

Left & Right Lenses require cleaning. First rub with a Windex wet Kimwipe. If that will not clean, soak in concentrated nitric acid for 1 hour. The analyzer window on the connection to attachment side also requires cleaning. Use wet Kimwipe only!

- 2. Cleaning Furnace:** At the end of the runs with furnace still hot—Disconnect two quick connect fittings from the furnace and filter scrubber end. Use a shop vacuum to suck the spilled soda from the front of the furnace intake (where you insert the ladle). Apply vac. for 10 seconds.

- a. On **cooled** Oven Loosen Thumb Screw (Picture 7.2).



Picture 7.2

- b. Slide Apart (Horizontal Plane) (Picture 7.3).

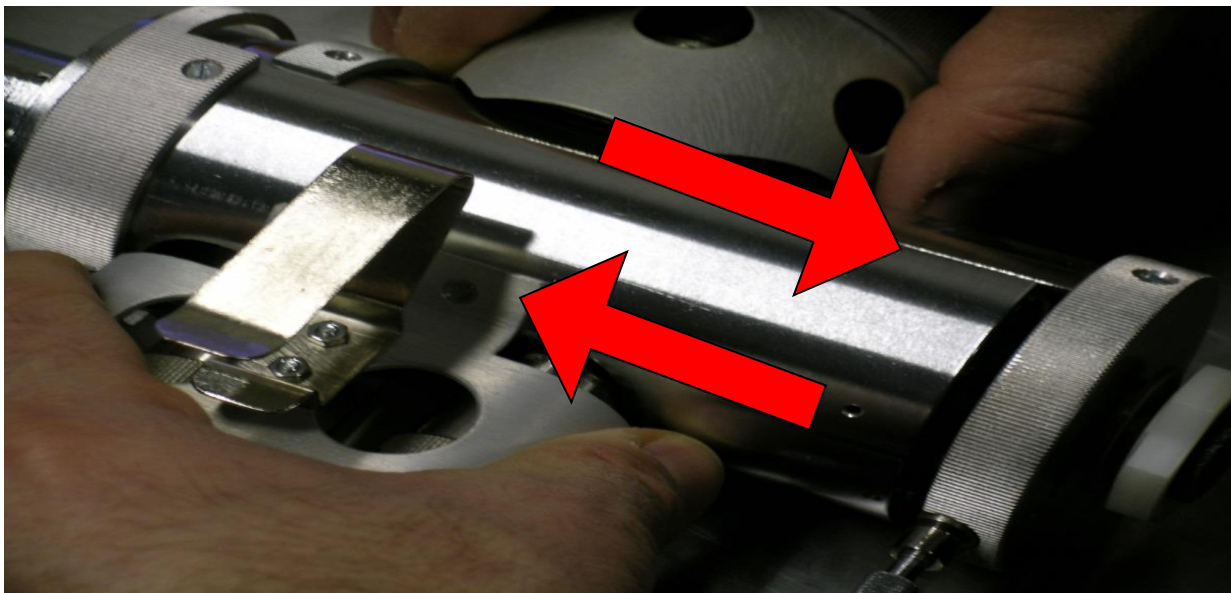

Picture 7.3

- c. Slide Cover Back (Pictures 7.4 – 7.5).



Picture 7.4

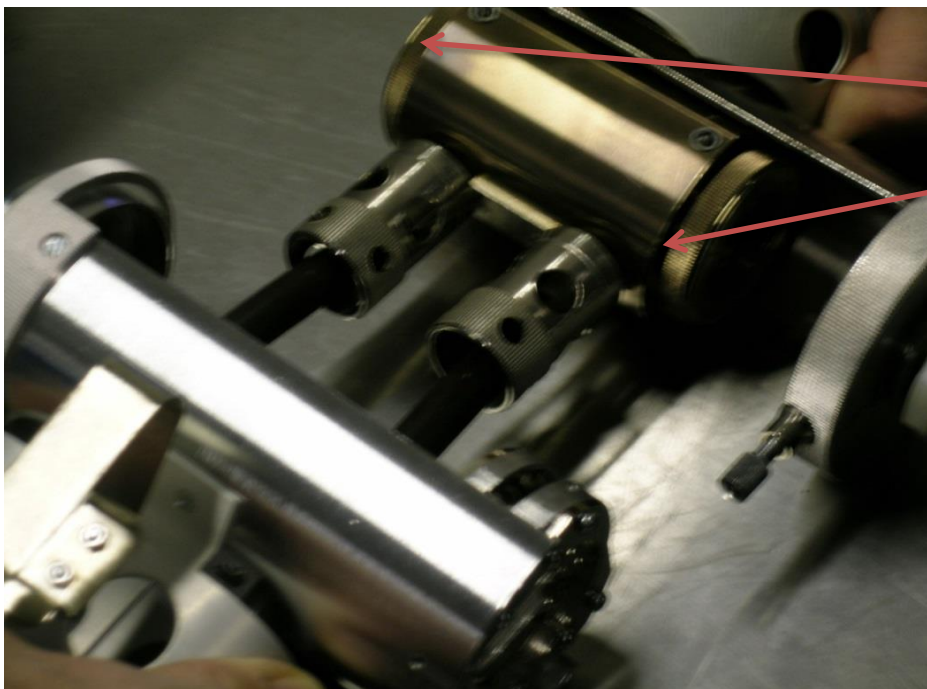

Note: Two  
Window  
holders  
If marked Left  
and Right-do  
not  
interchange

Picture 7.5

- d. **Warning!** Fragile parts inside. Turn Clockwise (5%) (Picture 7.6).



Picture 7.6

- e. Remove Carefully, Keep Plane Parallel to Cell Surface (Picture 7.7).

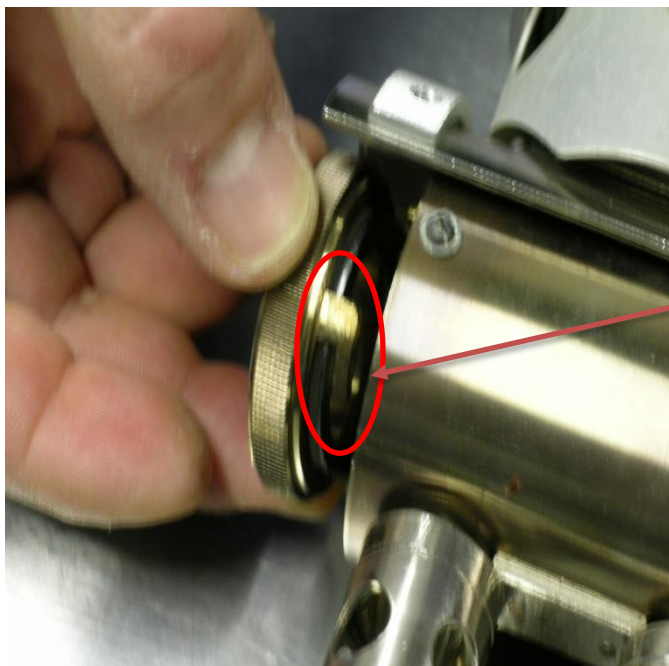

**Note:** Boss fittings  
Must be aligned to  
prevent quartz cell  
from breaking-Keep  
surfaces parallel.

**Note:** in latest design  
cells are metal.

Picture 7.7

f. Quartz Cell (Picture 7.8).

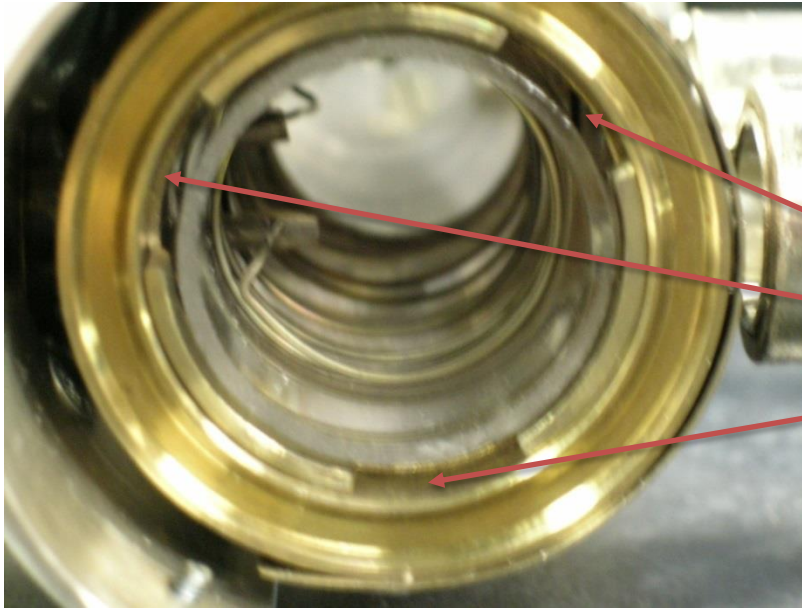

**Note:** Boss Must be aligned to prevent quartz cell from breaking-Keep surfaces parallel

In latest design cell is made from stainless silco coated.

Picture 7.8

g. Remove Right and Left Lenses (Picture 7.9).

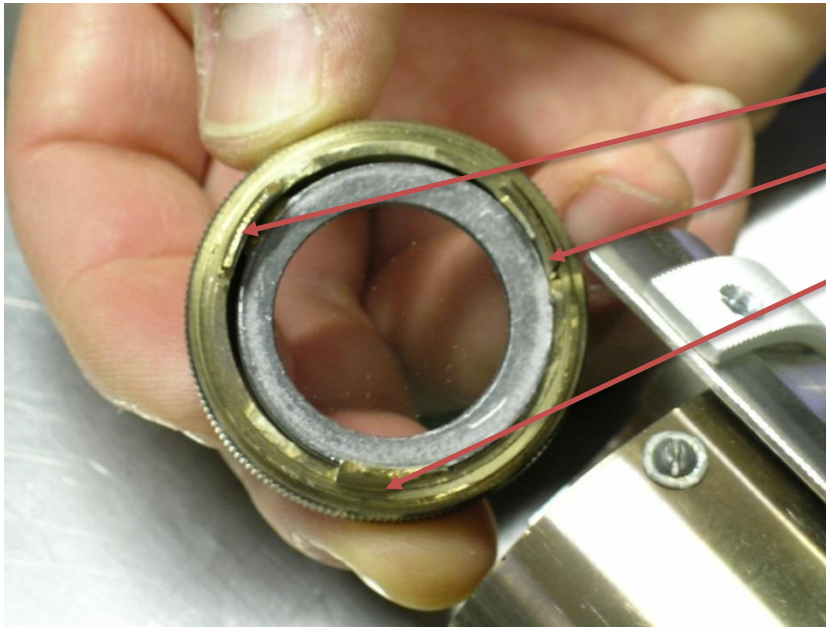

Bosses  
(Bayonete  
Fittings)

Picture 7.9

- h. Remove Graphite Gasket and Window. Gasket must be compressed tightly and have no “wrinkles” (Picture 7.10 and 7.11).



Picture 7.10



Picture 7.11

- i. Reassemble Lenses (Pictures 7.12 and 7.13).

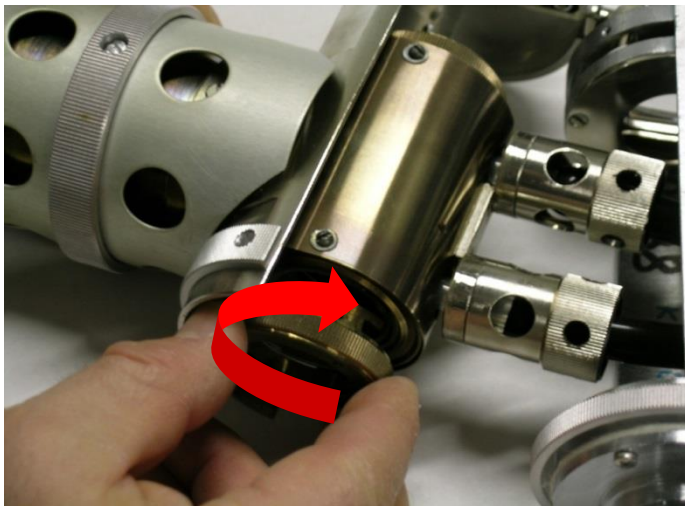

Picture 7.12

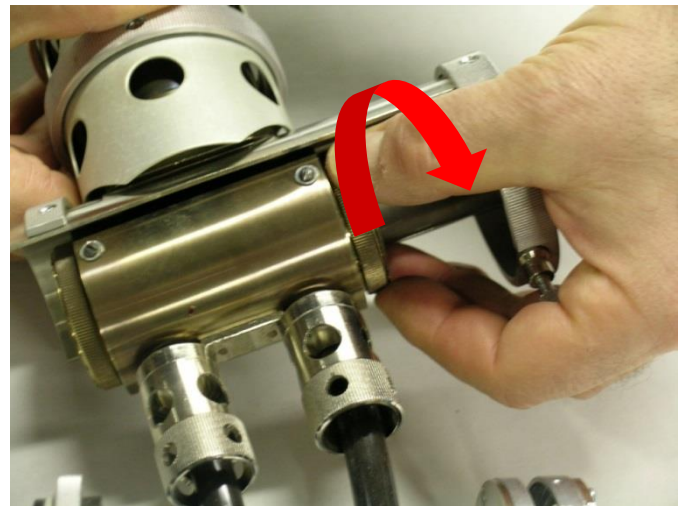

Picture 7.13

- j. Hoses will become brittle: Unscrew Hose Guards – Use Caution: Fragile Quartz Cell and Hose fittings (Picture 7.14).

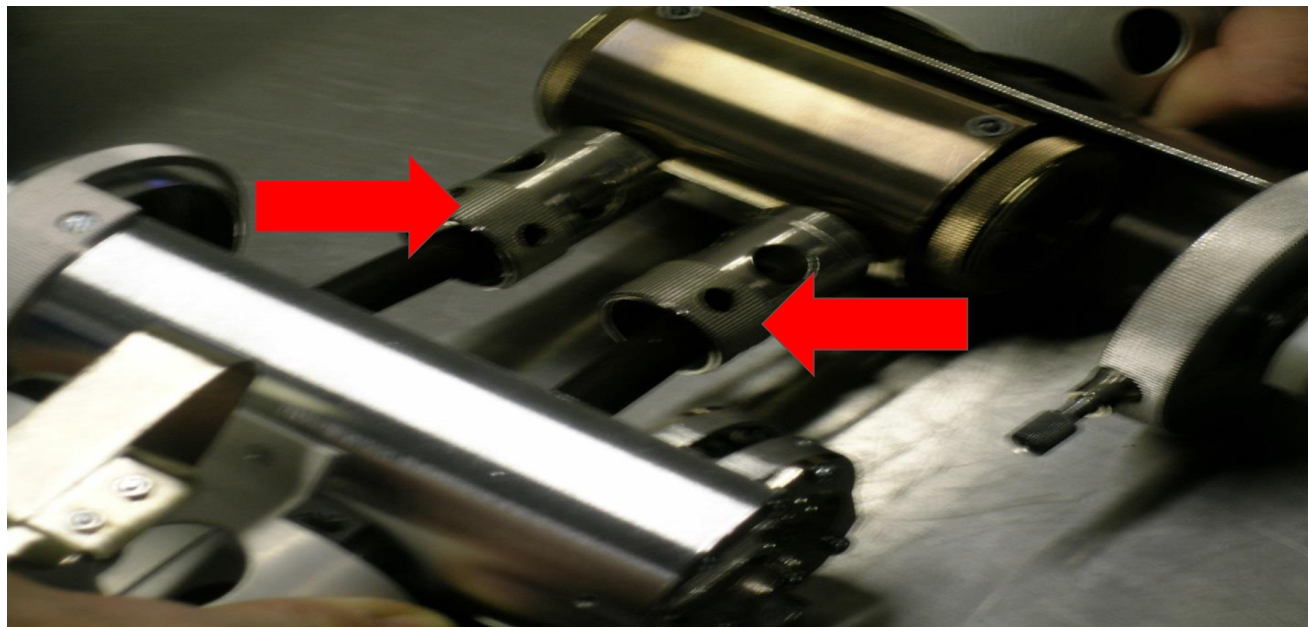

Picture 7.14

- k. To Replace Hose, cut and peel with box cutter knife (Pictures 7.15 – 7.16).



Picture 7.15

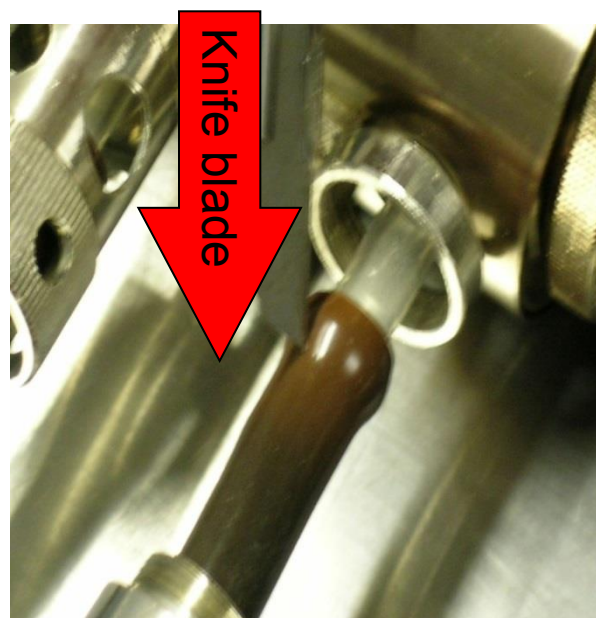

Picture 7.16

- I. Peel off carefully and scrape all debris off with knife (Picture 7.17).



Picture 7.17

- m. Dip hose in water to lubricate and insert onto quartz barb ½ inch (Pictures 7.18 – 7.20).



Picture 7.18



Picture 7.19



Picture 7.20

- n. Secure Carrier Gas Hose Guards (Picture 7.21).



Picture 7.21

- o. Heating cartridge replacement and reattaching cover: **Warning** - do not forget to use the soft sealing gasket (comes with replacement cartridge) between heating cartridge and furnace (Picture 7.21).



Replicable heating cartridge

Remove four screws positioned around the flange

Picture 7.21

- p. Tighten Securely (Picture 7.22).

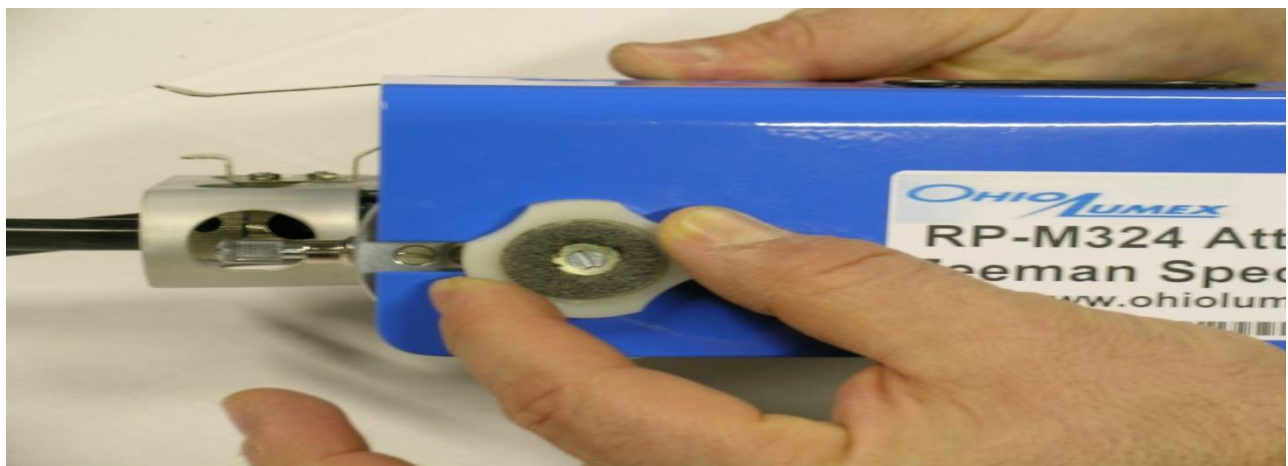

Picture 7.22

### 3. Heating cartridge cleaning

Unscrew four small bolts holding cartridge flange to furnace. Pull cartridge out. Use Vinegar and weak solution of hydrogen peroxide 9:1 mixture to clean cartridge from excess of soda and iodine. Leave cartridge in the mixture for 15 minutes, wash with tap water and dry in the same position (coil down) as presented on pictures. Prevent water from getting inside the cartridge “head” (Pictures 7.23 and 7.24). **Warning:** do not get liquid inside the flanged part of the cartridge.



Picture 7.23

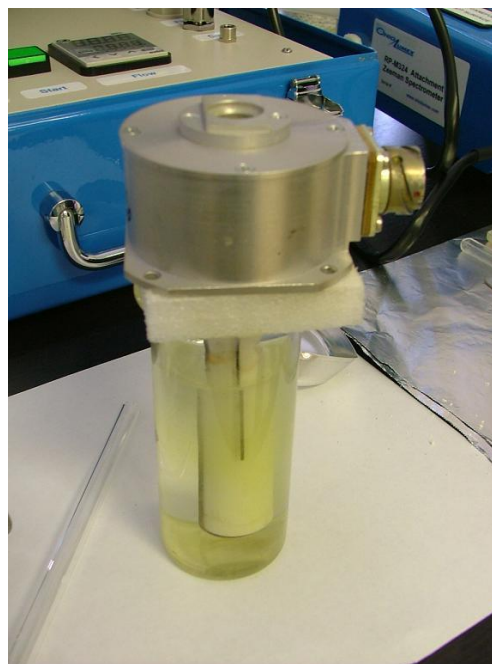

Picture 7.24

### 4. Pump

The Mass Flow controller maintains constant pump flow and usually does not require adjustments. Plugged filters or kinked hoses may cause pump to exceed auto compensation range, which causes an Alarm on the mass flow controller screen. If adjustments to flow rate are necessary, change flow set point by using the up & down arrows. Press Enter to store new set point. Flow for Profile 1 may be adjusted from 0.5 LPM to 2 LPM. Flow for Profiles 2, 3 & 4 is 4.0 LPM.

## 5. Shut Down Procedure

Save your work on computer in a designated folder BEFORE shutting down. Turn the Power Switch off on the pump station. Power Lumex Off by pressing the Power button on top of the analyzer. To preserve lamp, do not leave analyzer powered ON unless needed.

## Appendix A: User Experiences

1. Analyze Continuous Verification Standard after every paired train samples. This will prevent any invalid runs in the future.
2. Do not be afraid to recalibrate analyzer during analysis if you observe a consistent shift in Cont. Verif. Standard values. A 3-point calibration done in the middle of the day will only improve your data quality.
3. If a ladle comes out of the furnace with carbon burning in the middle and soda fused to quartz (happens only in profile 1) your furnace is too hot. This is major cause of broken ladles. Reset power of temperature controller without initiating Profile change by using the down arrow key on the controller to drop temperature from preset 680 to 650 or 630°C. This setting will be remembered by the controller, but will be overridden once profile 1 is initiated.
4. Use a lot of soda on top of the carbon. If you spill some inside the oven, **use a shop vacuum to suck the hot furnace from the ladle port intake (disconnect output hoses of the furnace from the filter to get the full flow). Remember to reconnect hoses!**
5. Never introduce samples or calibrate with the pump OFF or filters disconnected - furnace contamination will occur.
6. To clean furnace contamination, leave it ON overnight with Pump ON in profile 1 (analyzer should be OFF).

7. Baseline noise: a) dirty ladles—wash in hot water; b) contaminated furnace—see above; c) dirty windows—all windows need cleaning - 2 in the furnace and 1 on the analyzer.
8. If you expect continuous testing and would like to save on the furnace warm-up time in the morning, keep the pump and furnace on in profile 1 overnight.
9. To save time and minimize analysis, analyze front plug wool with the front section of carbon. Analyze the second section (breakthrough section) together with the plug before the section and the plug following it. Do the same for all other sections.
10. Maintenance:
  - a) use shop vacuum to clean the cell as noted earlier
  - b) clean windows and wipe the internal cell with wet (Windex) Kim Wipe periodically (every 100 - 200samples)
  - c) observe hoses on the furnace output for kinks or cracks
  - d) replace filter assembly once per year or when the pump starts to “cut out”.Dispose of Hazardous Materials per local regulations
11. Perform a leak test.

## Appendix B: Coal, Ash & Solids Analysis

1. Power furnace on, adjust temperature to 700°C, flow rate to 1 or 2 LPM then allow system to warm up for 45 minutes.

2. Calibration:

A) Calibration using Liquid Standards - Use 50 uL of 0.1 ug/mL standard, 100uL of 0.1ug/mL, use 50uL of 1ug/mL. The calibration chart should appear as shown below: (ng/g = ppb)

N	Sample Description	ref. data	C, ng/g	Area
1	100 ppb	50	100	740
2	100 ppb	100	100	1480
3	1000 ppb	50	1000	7400

B) Alternative Calibration using single point calibration - Use NIST Coal Standard 1632d (Hg concentration 92.8ppb) or NIST Ash 1633c (Hg concentration 1.00 ppm).

N	Sample Description	ref. data	C, ng/g	Area
1	92.8 ppb	176 93	4220	

3. Prepare Standard or \*Coal/Ash sample.

\*For coal/ash standards, weigh from 100 to 200 mg using a 1mg resolution balance. Load standard into ladle spreading evenly on the mid to front bottom part of the ladle. Cover with a layer of Ohio Lumex carbon then fill ladle to the top with sodium carbonate. Wipe away excess sodium carbonate then compress ladle sample with foil. Analyze as usual. Analysis time is close to 120 seconds.

4. Results will be reported in Calculated, ng/g (ppb) column on an AS IS basis.



9263 Ravenna Rd., Suite A-3  
Twinsburg, OH, 44087  
Toll Free: 888-876-2611

## **APPENDIX C: SORBENT TRAP ANALYSIS PROCEDURE**

Subject

Mercury Emissions Monitoring Program  
Sorbent Trap Analysis

Prepared by

Analytical Laboratory of Ohio Lumex Company

Revised on October 23, 2013

## 1. INTRODUCTION TO THE ANALYSIS METHOD WITH THE RA-915M/RP-M324 MERCURY ANALYZER SYSTEM

This document describes the procedure of sorbent trap analysis using the Ohio Lumex RA915M with the RP-M324 attachment for total mercury (**Hg**) determination by thermal decomposition with atomic absorption and Zeeman Correction.

The analytical method at Ohio Lumex is based on the thermal desorption per EPA Method 7473 (direct thermal desorption with atomic absorption and no gold amalgamation). The method is applicable for total mercury “direct” testing of 40 CFR Part 75 PS-12B, EPA Method 30B sorbent traps, and speciated mercury measurement sorbent traps. The reporting limit (RL) is equal to the method detection limit (MDL) determined for the instrument of total mercury testing.

Analysis time depends upon the temperature and flow rate of the analyzer pump station. Typically, the run time is about 90 seconds per sample.

The required instrument and accessories for performing the analysis include,

- Ohio Lumex- RA 915M with RP-M324 Attachment;
- Computer;
- Ohio Lumex 6 inch ladles;
- Assorted laboratory equipment, which includes spatulas, glass wool extractor, tweezers, adjustable pipettes, aluminum weigh boats, aluminum foil, torch, trap cutter and so on.

Reagents and standards include,

- NIST-certified and NIST- traceable mercury calibration standards;
- Second source NIST standard;
- Sodium Carbonate;
- Calibration sorbent media – activated, iodinated Carbon.

Although the Zeeman correction used by the Ohio Lumex analyzer eliminates spectral interferences in the analyzer, halogens and especially iodine and chlorine will form acid gases in the furnace. These acid gases will react with the elemental mercury and plate out mercury salts on the optical lenses in the analytical chamber. Therefore, granular sodium carbonate is ALWAYS placed on top of the sorbent media to capture the acid gas and eliminate the acid gas interferences. Calibration substrate is the same media in the sorbent trap. If a different substrate is used as the calibration purpose, calibration adaptability to the different media must be demonstrated before analyzing any trap.

## **2. ANALYTICAL PROCEDURE DETAILS**

The sorbent trap tube end cap is removed. The empty portion of the tube before the first plug should be cut down using a Dremel cutter blade. Using the tweezers or extractor, the glass wool plug at the front of the appropriate sorbent bed is carefully removed and separated from the sorbent faction. The sorbent is transferred into a quartz ladle and then covered with anhydrous sodium carbonate. The ladle is inserted into the analyzer's thermo catalytic conversion chamber. As a result, elemental mercury ( $\text{Hg}^0$ ) is liberated into the gas stream and oxidized mercury ( $\text{Hg}^{2+}$ ) is converted from a bound status to the atomic status by thermal decomposition in the furnace and is then detected by atomic absorption with Zeeman correction. The mercury concentration is measured and recorded using an automated data collection system. Both the glass wool plug and the sorbent of each section are analyzed and the final Hg mass is figured by adding the measurements together.

The procedure for the trap analysis is described here step by step,

### **2.1 Instrument Start-up**

### **2.2 Preliminary Determination of Mercury Mass**

### **2.3 Analyzer Calibration**

## 2.4 Preparation of Sorbent Traps for Analyzing and Analysis Procedure

## 2.5 Calibration Verification

## 2.6 Data Saving and Reporting

### 2.1 Instrument Start-up

- 2.1.1 Set up the connections among RA-915M analyzer, RP-M324 attachments and laptop computer. Analyzer setup with EZ-Zone controller is shown in Figure.
- 2.1.2 Connect power cord to RA-915M, RP-M324 and laptop computer.
- 2.1.3 Complete setup with heat shield.
- 2.1.4 Turn on computer.
- 2.1.5 Turn on RA-915M by pressing the power button on the top of the analyzer. The mercury lamp will ignite automatically.
- 2.1.6 Turn on the RP-M324 power supply. Warm up the analyzer and choose a proper profile to run. The carrier pump flow rate is bounded to the profiles of RP-M324 power supply system with EZ-Zone controller. When the profile is selected, the pump will automatically adjust to the desired flow rate.

The profiles and their setting information for EZ-Zone controllers are listed in Table 1.

- 2.1.7 Start the RA-915M software from the Windows main screen by double clicking the  icon. The RA-915M Main menu screen will appear.

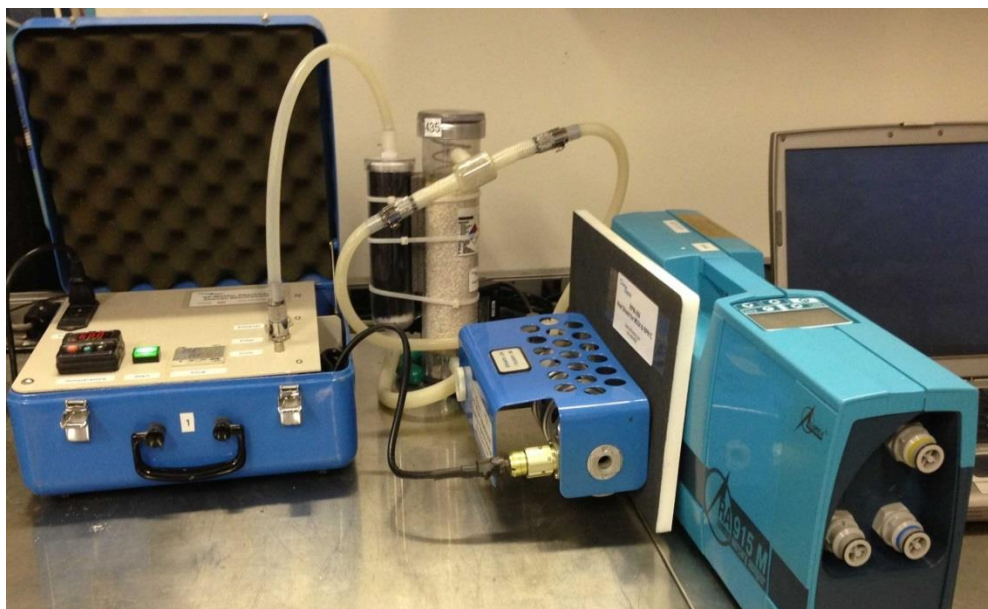



Figure 1. Analyzer setup with an EZ-Zone controller

- 2.1.8** Select “Sample Analysis” on RA-915M’s main menu screen then configure the window view to “Table to the right of the plot” by clicking the  icon.
- 2.1.9** Under the “Operating cell” drop down menu, select “External” and under the “Operation mode” drop down menu, select “Calibration.”
- 2.1.10** Click the “Start” button and allow the system to warm up for at least 45 minutes before calibration.
- 2.1.11** The average baseline value and the baseline RSD is located under the “Current signal” box to the right of where the “Operation mode” was adjusted. After 45 minutes, if the RSD is higher than 5, shut off the furnace, allow it to cool down, and clean the analytical cell windows.
- 2.1.12** No baseline check is necessary with the RAPID software.

## 2.2 Preliminary Determination of Mercury Mass

The expected mercury mass is an estimate of the total mercury collected in section 1 of a sorbent trap. The estimation for this amount is very important to decide the calibration range and choose a profile.

Knowledge of estimated stack mercury concentrations and total sample volume may be required prior to analysis. Information may be received from the stack testers. However, an analyst should always evaluate the traps based on the information shown in the “Chain of Custody”, i.e. the sampling duration, flow rate, duct temperature, meter temperature, dry gas volume, and pre-spiked Hg-mass. A proper testing profile can be chosen after the evaluation. Table 1 shows the most current profiles for the Ohio Lumex M324 pump station with an EZ-Zone Controller.

Table 1. Profiles and Settings of an EZ-Zone Controller

<b>Profiles</b>	<b>Starting Temp.  (°C)</b>	<b>Flow Rate  (L/min.)</b>	<b>Test Range  (ng)</b>	<b>Duration  (sec.)</b>
<b>1</b>	680	0.5-2.0	2-300/10- 2,000	100
<b>2</b>	652	4.0	10-4,000	120
<b>3</b>	653	4.0	5,000-10,000	350
<b>4</b>	654	4.0	10,000-30,000	700
<b>**</b>	585	0.5	2 - 300	180-220

*\*\* EZ-Zone Controller settings for speciation traps only. No profile configured, parameters must be adjusted manually.*

### 2.3 Analyzer Calibration

A certified analyzer is used to test sorberent traps. The analyzer certificate provides the information on Method Detection Limitation (MDL), bias and spike recovery study results. MDL is the minimum amount of the analyte that can be detected and reported. It is statistically derived from replicate low level measurements near the analytical instrument's detection level. The bias test demonstrates the analyzer's ability to recover and accurately quantify  $Hg^0$  and  $HgCl_2$  from sorberent media. The bias test is performed at a minimum of two distinct sorberent trap Hg loadings that represent the lower and upper bound of sample  $Hg$  loadings from application. A Spike recovery study is required by Performance Specification 12B (PS-12B). It shows the ability of laboratory to recover and quantify Hg from sorberent media traps spiked with elemental mercury. The analyzer certificate is available upon customer request.

It is important to clean ladles and tools before testing any standards or samples. Mercury deposited on the ladle would influence the calibration and testing. By inserting an empty ladle into a heated furnace (Temperature  $>500^{\circ}C$ ) for at least 90 seconds, any potential mercury contamination on the ladle will be removed. The glass wool extractor and tweezers should also be cleaned using a torch by burning the ends of both instruments for approximately 5 seconds. Calibration sorberent media must be stored in a sealed container. Any media exposed to air for more than 5 hours should not be used for calibration purposes.

Only National Institute of Standards and Technology (NIST) certified or NIST traceable calibration standards and standard reference materials should be used for the analytical procedures. The entire set of Ohio Lumex calibration standards consists of 0.01  $\mu g/ml$ , 0.1  $\mu g/ml$ , 1.0  $\mu g/ml$ , 10.0  $\mu g/ml$ , 100.0  $\mu g/ml$ , 1000.0  $\mu g/ml$  and second source of 0.1  $\mu g/ml$ , 1.0  $\mu g/ml$ , 10.0  $\mu g/ml$ , 100.0  $\mu g/ml$   $Hg^{2+}$  solution. Depending on the calibration range, not all standards are needed to make a calibration. Section 11.1 of Method 30B states that the user must "Perform a multipoint calibration of the analyzer" using at least

three calibration points. The expiration date of a standard must always be checked before a calibration is run.

Manufacturer concurs with state and federal regulatory agencies' recommendations that solution standards be assigned a one-year expiration date. The expiration date is printed in the document of standard certification.

### 2.3.1 Calibration Procedure

**\*Note: This SOP only outlines the Mark & Integrate method of calibration and analysis using the Ohio Lumex RAPID Computer Software.**

- 1) **RUNNING CALIBRATION POINTS:** Review *Table 1. Profiles and Settings for an EZ-Zone Controller* and select proper profile range.
- 2) Double check that "Calibration" is selected under the Operation Mode drop down menu. Fill in the "Sample Description" and "ref. data" with the expected calibration point mass (if calibration point is 10 ng, then place the number 10 in "Sample Description" and "ref. data" rows). The number 1 should always be placed in the "Mass/Volume" row whether running calibration points or analyzing sorbent traps.
- 2) Place calibration sorbent into ladle and pipette the desired volume of the appropriate standard onto the sorbent (For example, 100  $\mu$ l of .10  $\mu$ g/ml standard equals 10 ng mercury, enter 10 in both the "Sample Description" and "ref. data" row).
- 3) Cover the sorbent with anhydrous sodium carbonate.
- 4) Gently pack the sorbent and sodium carbonate in the ladle by covering the opening with a piece of aluminum foil and compressing the solids through the foil with your finger. Sodium carbonate must completely cover the sorbent. Remove the aluminum foil from the ladle before analysis.

- 5) Click the **Mark** button located in the lower left hand portion of the software window and immediately insert the prepared ladle into the furnace. Note: The **Mark** button will change to **Mark and Integrate**.
- 6) The mercury signal is shown as red on the graph. The reading of the current value is shown in the box to the right of the graph in the “Signal” column.
- 7) Once the current value readings have spiked and returned to the original starting point, and the RSD reading value is around the originally static value, click the **Mark and Integrate** button located in the lower left hand portion of the software window to stop the analysis run.
- 8) Remove the ladle from the furnace and place on a heat-resistant surface (aluminum foil). Once cooled, dispose ladle contents into a heat-resistant (metal) tray.
- 10) Repeat steps 1 thru 9 until three or more calibration points have been run.
- 11) **CREATING CALIBRATION CURVE:** Click the check mark box in the far left column next to each calibration point you want used in the calibration curve.
- 12) Click the “Calculate calibration” button in the lower right hand portion of the software window.
- 13) On the pop up window under “Data view” click “Table view” and use the left to right scroll bar to locate the “Calculated, ng/g” and “d, %” columns.
- 14) Calibration is valid if calculated calibration points are within  $\pm 10\%$  of expected value AND calibration correlation coefficient ( $R^2$ ) is  $\geq 0.99$ .
- 15) Give a name to the calibration and click save (Example: 10.10.13\_Cal Curve).

### 2.3.2 Calibration Criteria

Multipoint calibration is required. Three or more standards should be used to make a calibration curve. An independent standard, for example a NIST solid standard or a NIST traceable mercury standard from a separate lot, will be analyzed to ensure the accuracy of the calibration.

The calibration criteria is,

- 1) Calibrations must be performed on the day of the analysis, before analyzing any of the samples;
- 2) Three or more upscale calibration points must be used;
- 3) The lowest point in the calibration curve must be at least 5, and preferably 10 times the MDL.
- 4) The field samples analyzed must fall within a calibrated, quantitative range and meet the performance criteria of Method 30B or PS-12B;
- 5) For each calibration curve, the value of the square of the linear correlation coefficient, i.e. ,  $R^2$  , must be  $\geq 0.99$ , and the analyzer response must be within  $\pm 10\%$  of the reference value at each upscale calibration point;
- 6) Following calibration, and an initial calibration verification standard (ICVS) or a second source standard must be analyzed. The measured value of the independently prepared standard must be within  $\pm 10\%$  of the expected value;
- 7) The analysis of blanks is optional, yet must not be used in calibration.

The **Hg** amount in each sample must fall into the calibrated range of the analyzer, and within the lower and upper mass limits established during the initial **Hg<sup>0</sup>** and **HgCl<sub>2</sub>** analytical bias test. For extra low-level samples (**Hg** mass is below the lowest point in the calibration curve and above the MDL), a response factor (e.g. area count per **Hg** mass) is established based on a single standard at level greater than the MDL and less than the lowest point in the calibration. The amount of **Hg** present in the sample is calculated based on the analytical response and this response factor.

## 2.4 Preparation of Sorbent Traps for Analysis and Analysis Procedures

- 1) The end cap of a sorbent trap is removed and the trap is scored using a Dremel glass cutter just above the first glass wool plug. The trap should then be broken at the score mark.
- 2) Carefully remove the first glass wool plug and tightly wrap it in a small piece of aluminum foil. Be sure entire plug is covered.
- 3) Transfer the sorbent AND proper plug rolled in foil into a quartz ladle and then cover with anhydrous sodium carbonate until the ladle is full.
- 4) Cover the ladle opening with a piece of aluminum foil and finger press the materials in the ladle. Be sure no sorbent is exposed through the sodium carbonate.
- 5) The ladle is now ready for analysis and may be run in accordance with steps 5 thru 8 listed under section 3.3.1 Calibration procedure.

Note: The glass wool plug wrapped into aluminum foil may be analyzed separately if both the plug and the sorbent don't fit into a single ladle.

Some traps come with dust pre-filter or acid gas scrubber (AGS) section. The pre-filter and AGS are part of the total mercury collected during sampling, however, they are tested and reported independently from the other sorbent sections.

**Description and analysis procedures for Ohio Lumex Sorbent Traps**

**(1) PS-12B Trap**

Figure 1. is an illustration of a three section PS-12B sorbent trap. These traps are commonly used for compliance reporting. The first section is the primary flue gas mercury capture, the second section is the breakthrough section and the third section is a spiked QA/QC section. According to flow direction, each sorbent section is labeled as S1, S2 and S3 while the glass wool plugs are labeled P1, P2, P3 and P4 respectively. The analysis flow chart of a PS-12B trap is illustrated in Figure 1.2.

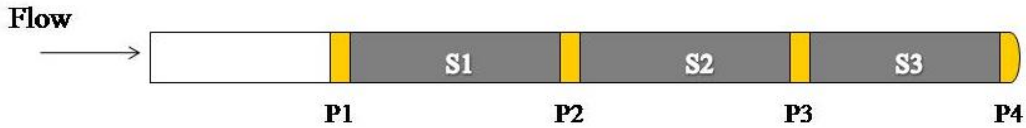

Figure 1. Illustration of a PS-12B Trap

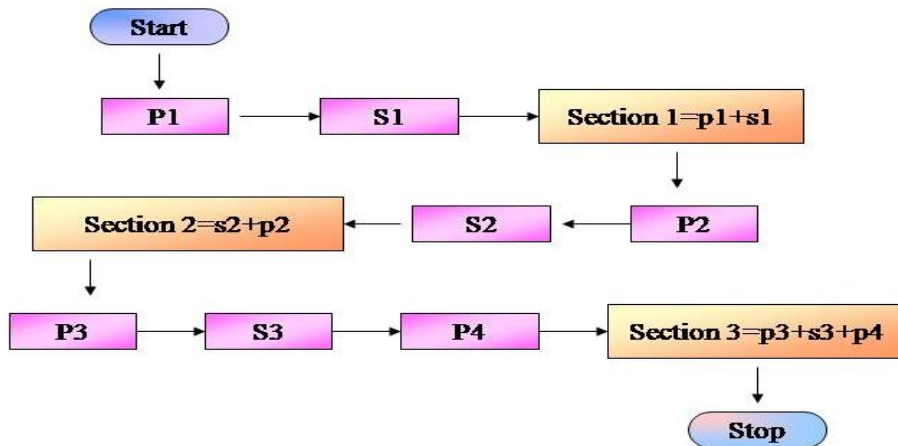

Figure 1.2 Analysis procedure for PS-12B Traps

**(2) 30B Trap**

A 30B trap (Figure 2) is a two-section trap most commonly used for RATAs and short term testing projects. The glass wool plugs and sorbent sections are labeled along the same guidelines as the PS-12B traps. The first section (S1) quantitatively captures Hg and the second section (S2) is used for the breakthrough calculation. The testing procedure for a 30B trap is shown in Figure 2.1.

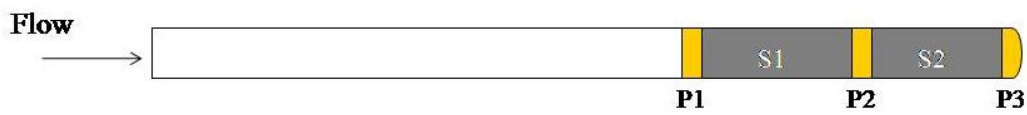

Figure 2. Illustration of a 30B Trap

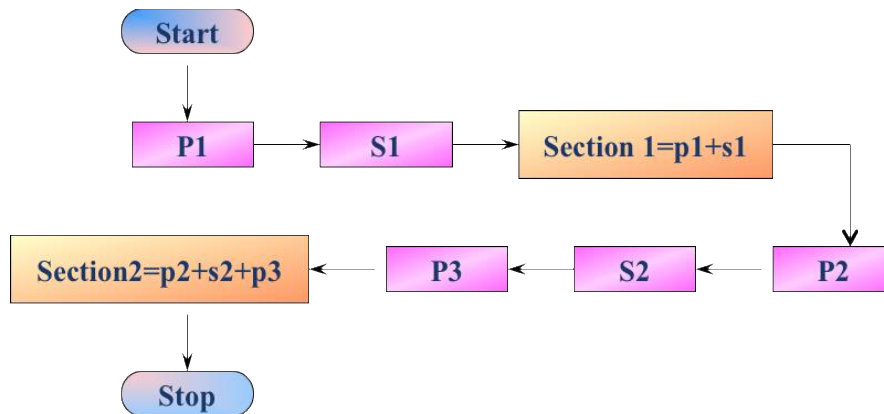
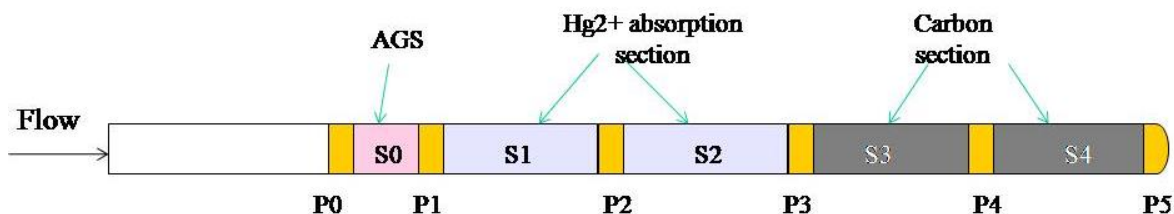

Figure 2.1 Analysis procedure for 30B Traps

### (3) Speciation Trap

The speciation trap is a 5 sections trap (Figure 3.). Section zero or simply “S0” is the AGS section. Following the AGS, the first two potassium chloride (KCl) sections (used for capturing oxidized mercury) are labeled sections one and two or simply “S1” and “S2” respectively. The final two carbon sections (used for elemental mercury capture) are labeled sections three and four or simply “S3” and “S4”.

S0, S1 and S2 should be analyzed at a temperature 585°C. S3 and S4 may also be analyzed at a temperature of 585°C, however, if you wish to speed up the analysis time, a temperature of 680°C may be used as well.



S0 = Acid Gas Scrubber (AGS)

S1 = Oxidized Mercury Analytical Bed (KCl)

S2 = Oxidized Mercury Breakthrough Bed (KCl)

S3 = Elemental Mercury Analytical Bed (Carbon)

S4 = Elemental Mercury Analytical Bed (Carbon)

Figure 3. Illustration of a Speciation sorbent trap

### Special Considerations for Analyzing Speciation Traps

- KCl sections *MUST* be analyzed at a temperature of 585°C and 0.5 L/min.
- Separate calibration curves must be developed if KCl and Carbon sections are analyzed at different temperatures.
- Melting or fusing of the KCl with the sodium carbonate indicates overheating. Drop the temperature 10 to 20 degrees.
- Extended analysis time (over 300 seconds) indicates too low of a temperature set point. Increase temperature 10 to 20 degrees.

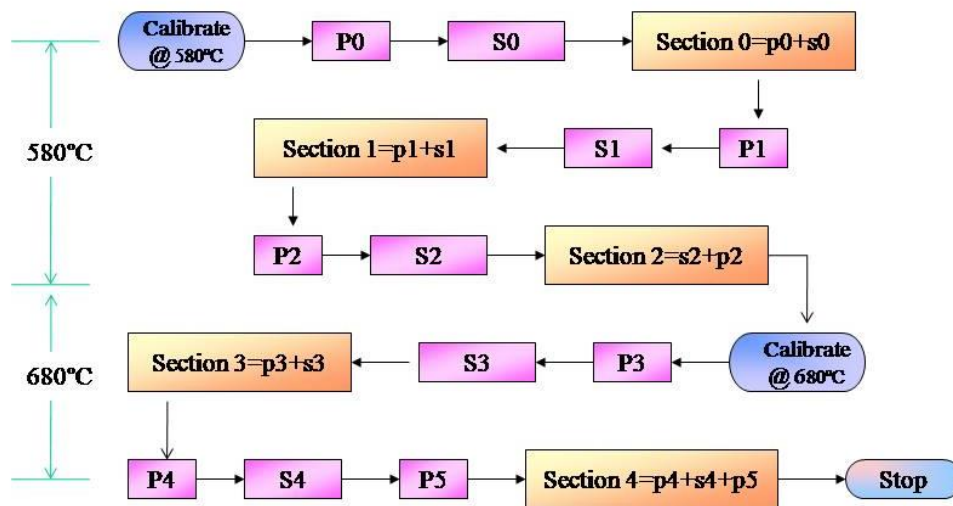

Figure 3.1 Analysis procedure for Speciation Traps

#### (4) Trap with AGS or dust filter

Some traps come with Ohio Lumex particulate (dust) pre-filter (static or coil) or AGS section. The pre-filter or AGS section is named as “S0” and tested separately with other sections. An example of a trap is illustrated in Figure 4. Test procedure is shown in Figure 4.1.

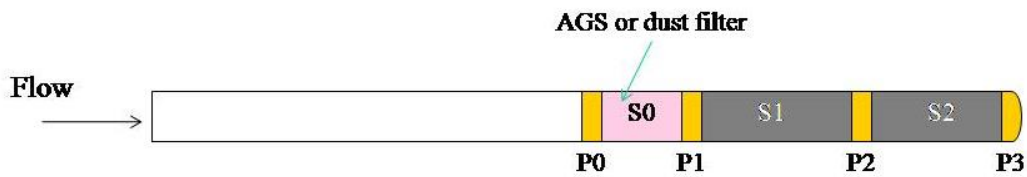

Figure 4. Trap with AGS or Particulate (dust) Pre-Filter

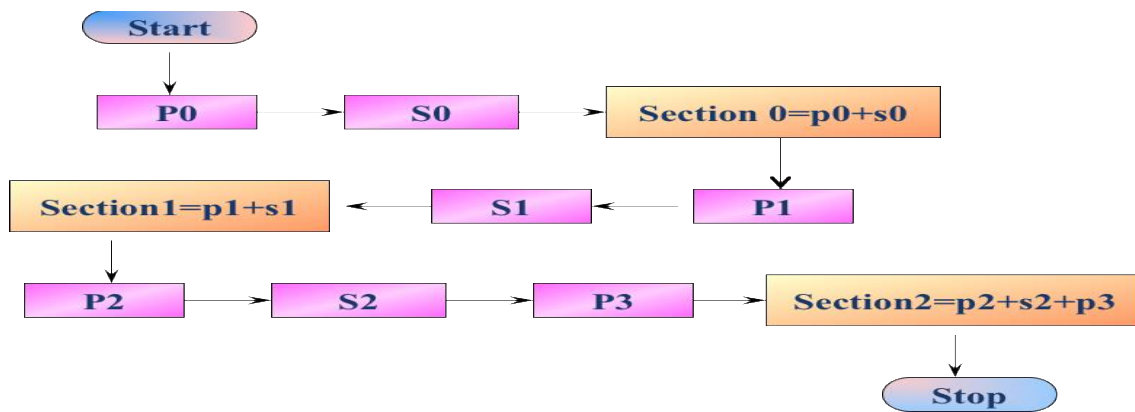

Figure 4.1 Analysis procedure for trap with AGS or Particulate (dust) Pre-Filter

## **2.5 Continuous Calibration and Post-Calibration Verifications**

### **2.5.1 Analysis of Continuing Calibration Verification Standard (CCVS)**

After no more than 10 analyses, a continuing calibration-verification standard must be analyzed. The standard should fall into the calibration range. The measured value of the CCVS must be within  $\pm 10\%$  of the expected value.

### **2.5.2 Post-Calibration Verification**

At the end of each set of analysis, a calibration standard will be tested. The standard should be within the calibration range and the measured value of this standard must be with  $\pm 10\%$  of the expected value.

## **2.6 Data Saving and Reporting**

At the end of testing, all data should be saved in the Ohio Lumex database. Data can be reported as an Excel file, (\*.xls), pdf file (\*.pdf) or in a report format (\*.qrp). Customer can request an extended laboratory report from the Laboratory.

An extended lab report includes the following,

- 1) Analyzer certificate;
- 2) Mercury standards certificates;
- 3) A formal report, showing all standards and traps testing time, sequence and corresponding results;
- 4) Pre-calibration report;
- 5) Post-calibration verification report.

**3. TERMS AND DEFINITIONS**

AGS	Acid Gas Scrubber
PS-12B	Quality assurance and operating procedures, published by US EPA for sorbent trap monitoring systems
Blank-	Any raw carbon sample not spiked with liquid mercury solution or elemental mercury gas.
Calibration Standards-	NIST certified or traceable mercury standards used to determine an instrument calibration.
CCVS	Continuing Calibration Verification Standard
Hg	Mercury
Hg <sup>0</sup>	Elemental Mercury
Hg <sup>2+</sup>	Oxidized Mercury
0.1.1.1 HgCl <sub>2</sub>	Mercuric Chloride
0.1.1.2 HCl	Hydrochloric Acid
Independent standards-	NIST traceable or certified mercury standards from separate lot or manufactures than the calibration standards.
MDL-	Method detection limit - the lowest mass of Hg greater than zero that can be estimated and reported by your analytical technique
Method 30B	a procedure, published by US EPA, for measuring total vapor phase mercury emissions from coal-fired combustion source using sorbent trap sampling and an extractive or thermal analytical technique.
NIST	National Institute of Standards and Technology, located in

	Gaithersburg, Maryland
Profile	A temperature control program, loaded into EZ-Zone Controller by Ohio Lumex Company prior to shipping the system to the end user
RATA	Relative Accuracy Test Audit
Sorbent –	Media used in traps to adsorb mercury. May be halogenated or non-halogenated
Trap –	Glass tube packed with one, two, three or more beds of sorbent held in place and separated by glass wool. The sample trap is placed in the sampling probe and flue gas is pulled through the sample trap. The carbon in the trap adsorbs mercury, which is then used to determine the mercury concentration in the flue gas.

#### 4. CALCULATIONS AND DATA ANALYSIS

\*All calculations and data analysis are explained in section 12.0 of Method 30B. These calculations are listed below:

Nomenclature. The terms used in the equations are defined as follows:

B = Breakthrough (%)

$B_{ws}$  = Moisture content of sample gas as measured by Method 4, percent/100

$C_a$  = Concentration of Hg for the sample collection period, for sorbent trap “a” ( $\mu\text{g}/\text{dscm}$ )

$C_b$  = Concentration of Hg for the sample collection period, for sorbent trap “b” ( $\mu\text{g}/\text{dscm}$ )

$C_d$  = Hg concentration, dry basis ( $\mu\text{g}/\text{dscm}$ )

$C_{rec}$  = Concentration of spiked compound measured ( $\mu\text{g}/\text{m}^3$ )

$C_w$  = Hg concentration, wet basis ( $\mu\text{g}/\text{m}^3$ )

$m_1$  = Mass of Hg measured on sorbent trap section 1 ( $\mu\text{g}$ )

$m_2$  = Mass of Hg measured on sorbent trap section 2 ( $\mu\text{g}$ )

$m_{\text{recovered}}$  = Mass of spiked Hg recovered in Analytical Bias or Field Recovery Test ( $\mu\text{g}$ )

$m_s$  = Total mass of Hg measured on spiked trap in Field Recovery Test ( $\mu\text{g}$ )

$m_{\text{spiked}}$  = Mass of Hg spiked in Analytical Bias or Field Recovery Test ( $\mu\text{g}$ )

$m_u$  = Total mass of Hg measured on unspiked trap in Field Recovery Test ( $\mu\text{g}$ )

R = Percentage of spiked mass recovered (%)

RD = Relative deviation between the Hg concentrations from traps "a" and "b" (%)

$v_s$  = Volume of gas sampled, spiked trap in Field Recovery Test (dscm)

$V_t$  = Total volume of dry gas metered during the collection period (dscm)

For the purposes of this method, standard temperature and pressure are defined as 20° C and 760 mm Hg, respectively.

$v_u$  = Volume of gas sampled, unspiked trap in Field Recovery Test (dscm).

12.2 Calculation of Spike Recovery (Analytical Bias Test). Calculate the percent recovery of  $\text{Hg}^0$  and  $\text{HgCl}_2$  using Equation 30B-1.

$$R = \frac{m_{\text{recovered}}}{m_{\text{spiked}}} \times 100 \quad \text{Eq. 30B-1}$$

12.3 Calculation of Breakthrough. Use Equation 30B-2 to calculate the percent breakthrough to the second section of the sorbent trap.

$$B = \frac{m_2}{m_1} \times 100 \quad \text{Eq. 30B-2}$$

12.4 Calculation of Hg Concentration. Calculate the Hg concentration measured with sorbent trap "a", using Equation 30B-3.

$$C_a = \frac{(m_1 + m_2)}{V_t} \quad \text{Eq. 30B-3}$$

For sorbent trap "b", replace " $C_a$ " with " $C_b$ " in Equation 30B-3. Report the average concentration, i.e.,  $\frac{1}{2}(C_a + C_b)$ .

12.5 Moisture Correction. Use Equation 30B-4 if your measurements need to be corrected to a wet basis.

$$C_w = C_d \times (1 - B_{ws}) \quad \text{Eq. 30B-4}$$

12.6 Calculation of Paired Trap Agreement. Calculate the relative deviation (RD) between the Hg concentrations measured with the paired sorbent traps using Equation 30B-5.

$$RD = \frac{|C_a - C_b|}{C_a + C_b} \times 100 \quad \text{Eq. 30B-5}$$

12.7 Calculation of Measured Spike Hg Concentration (Field Recovery Test). Calculate the measured spike concentration using Equation 30B-6.

$$C_{rec} = \frac{m_s}{v_s} - \frac{m_u}{v_u} \quad \text{Eq. 30B-6}$$

Then calculate the spiked Hg recovery, R, using Equation 30B-7.

$$R = \frac{C_{rec} \times v_s}{m_{spiked}} \times 100 \quad \text{Eq. 30B-7}$$

## 5. HEALTH AND SAFETY

### 5.1 Sampling Safety

If performing the test sampling, follow the Source/Plant safety protocol to ensure any hazards are avoided.

### 5.2 Laboratory Safety

Proper protective equipment (lab coats, safety glasses, particulate respirator, nitrile gloves) shall be worn while performing analysis.

### 5.3 Reagents

Please refer to the provided Material Safety Data Sheets for every chemical used in order to avoid injury or reactions.

## 6. REFERENCES

- 1) "Thermal analysis for field sorbent trap mercury testing, Instruction hand book", Ohio Lumex Company Inc., 2006
- 2) Method 7473- "Mercury in solids and solutions by thermal decomposition, amalgamation, and atomic absorption spectrophotometry", US EPA, 2007  
[www.epa.gov/sw-846/pdfs/7473.pdf](http://www.epa.gov/sw-846/pdfs/7473.pdf) .
- 3) Method 30B-"Determination of total vapor phase mercury emissions from coal-fired combustion sources using carbon sorbent traps", US EPA, 2008  
<http://www.epa.gov/ttn/emc/promgate/Meth30B.pdf>
- 4) Appendix K to Part 75-"Quality assurance and operating procedures for sorbent trap monitoring system", US EPA, 2005

## Appendix D:

# Determining the Method Detection Limit (MDL) for the Ohio Lumex RA-915+/RA-915M/RP-M324 Sorbent Trap Mercury Analyzers

In accordance with Method 30B, all analyzer systems must undergo an MDL Study. As a rule of thumb, the MDL is considered to be that amount of an analyte that creates a response (such as a peak) that is approximately 3 times greater than the average variance in response to a blank baseline. A commonly used method to determine an instrument's official MDL can be found in the EPA's SW-846 protocols. Using this method, 8 replicates of a low standard are analyzed and the MDL is defined as the standard deviation of the responses of the 8 measurements times 3.0. The significance of the "3.0" is that it is a factor for the statistical technique known as the "Student's T Distribution" which is used to determine an MDL with a 95% confidence level that you are actually seeing the analyte being measured (mercury) and not just baseline noise. If the number of replicates changes or if you want a confidence level other than 95%, you would use a factor other than "3.0". It's important to use a standard level for your replicates with a response not too much higher than what will be the MDL to get a good determination. Here are steps to perform an MDL determination on the Ohio Lumex Sorbent Trap Mercury Analyzer.

- Put the instrument in its most sensitive mode (profile 1) with the carrier flow at the lowest level that it will commonly be used in and the furnace in its most aggressive mode (680 °C at 2L/min).
- Calibrate the instrument as you would typically to make sure it's measuring with accuracy and precision (run 5 or 6 points typically from 10ng to 2,000ng) also run a blank and a second source standard.
- Using zero-mercury carbon, make and analyze 8 standards at a 3ng level.
- For these standards it is important that the mercury peak is isolated from

baseline noise during integration. This can be accomplished by either waiting to start integration about

- 30 seconds after the standard is inserted into the furnace and then promptly ending integration after the mercury has all been released, or by manually integrating the peaks.
- For these 8 replicates, calculate the average response in ng of mercury and the standard deviation in the responses in ng of mercury.
- The MDL is defined as 3 times this standard deviation.

As an example: If the 8 replicates of a 3ng standard produced responses of 2.79, 3.04, 2.89, 3.00, 2.67, 2.85, 3.04, and 3.17ng of mercury; the average response would be 2.93ng, the standard deviation would be 0.161ng and the MDL would be 3 times 0.161ng = 0.483ng.

## Appendix E:

### **Performing a Bias Test (Method 30B) and Spike Recovery Test (PS 12B) for the Ohio Lumex RA-915+/RA-915M/RP-M324 Sorbent Trap Mercury Analyzers**

Method 30B requires that prior to sample analysis a Bias Test be performed on the mercury analyzer. The PS 12B Method requires that a Spike Recovery Test be performed on the analyzer prior to analyzing samples using that method. Since the two tests are very similar, it is advantageous to perform them at the same time. This document will outline the steps necessary to perform the Bias Test and then list the extra steps to provide a valid Spike Recovery Test.

The Method 30B Bias Test is required in order to show that the analytical instrument is able to measure both elemental and oxidized mercury without bias. Three sorbent traps spiked with elemental mercury at each of two levels (a low level and a high level between which actual samples are expected to fall) are analyzed to demonstrate instrument accuracy in quantifying elemental mercury. Then, two sets of three standards made with aqueous mercury solutions are analyzed at the same mercury levels as the sorbent traps. As the water evaporates during analysis, for a short instance, the mercury exists as a mercury salt (oxidized mercury) until it is then broken down thermally and measured.

Here are steps to perform a Bias Test on the Ohio Lumex Sorbent Trap Mercury Analyzer.

- 1) Put the instrument in its most sensitive mode (profile 1) or in the configuration that you will use for analyzing 30B samples.
- 2) Calibrate the instrument as you would typically to make sure it's measuring with accuracy and precision (run 5 or 6 points typically from 10ng to 2,000ng) also run a blank and a second source standard. The calibration should meet the requirements of Method 30-B and the PS 12B method. Analyze Continuing Calibration Verification

Standards (CCVs) routinely as you continue.

- 3) Analyze three low-level traps (10ng or 20ng is a good level). The average recovery for the three traps must be within 10% of expected spike value.
- 4) Analyze three high-level traps (choose a level that is just below the highest point in your calibration to provide the maximum range). The average recovery for these three traps must be within 10% of expected spike value.
- 5) Next, make three standards using aqueous solutions (preserved in acid) at the same mercury mass level as the **low-level** spiked sorbent traps (i.e. 20ng in this example) and analyze them. The average recovery for these three traps must be within 10% of expected spike value.
- 6) Make three standards using aqueous solutions (preserved in acid) at the same mercury mass level as the **high-level** spiked sorbent traps and analyze them making sure that the average recovery for these three traps is within 10% of expected spike value.
- 7) If all the sets of three had average recoveries within 10% of expected spike values, the Bias Test meets the method guidelines and the analyzer can be used to analyze samples that have section-1 sample amounts between the high and low points that you chose. (Section-1 sample amounts below the amount you chose can be analyzed as well if they are from a low-level source).

#### **Additional Steps to Complete the PS 12B Spike Recovery Test**

Once the steps above have been performed, very little is needed to complete the Spike Recovery Test.

- 1) Analyze three sorbent traps spiked with elemental mercury at a medium-level that is between the low-level and high-level used above.
- 2) If the average recovery of these three sorbent traps is within 15% of the expected spike value, then these results and those of the spiked traps above represent a valid PS 12B Spike Recovery Test. Since the recovery requirement for the PS 12B method is within 15% of the expected spike value, the passing results for the 30B sorbent traps

within 10% of the expected spike value are more than adequate for this method.

## Appendix F:

### Performing a Spike Recovery Study (PS-12B) on the Ohio Lumex RA-915M/RP-M324 Sorbent Trap Mercury Analyzer System

A Spike Recovery Study must be performed in order to demonstrate the ability of the analytical system to recover and quantify elemental Hg from the sorbent media. Three 3-section PS-12B style traps are spiked at three different mass loadings representing the anticipated range of masses collected in the field samples.

Steps on how to properly perform a Spike Recovery Study on the Ohio Lumex RA-915M/RP-M324 Sorbent Trap Mercury Analyzer System are listed below.

- Put the instrument in the configuration you intend to use for analyzing PS-12B samples. This example uses Profile 2 settings.
- Calibrate the instrument by running 5 or 6 calibration points ranging 10ng - 4,000ng. Ensure the calibration is valid by running an Initial Calibration Verification Standard. The calibration should meet all the performance criteria as described in PS-12B. Analyze Continuing Calibration Verification Standards (CCVS) routinely as you continue.
- Analyze three low-level PS-12B spiked traps (10ng or 20ng). The average spike recovery for each trap must fall between 85% and 115% of expected mass.
- Analyze three mid-level PS-12B spiked traps (1,000ng or 2,000ng). The average spike recovery for each trap must fall between 85% and 115% of expected mass.
- Analyze three high-level PS-12B traps (3,000ng or 4,000ng). The average spike recovery for each trap must fall between 85% and 115% of expected mass.
- The Spike Recovery Study meets all the necessary guidelines outlined in PS-12B if all three sets of traps had average recoveries within 15% of expected spike

values. Spike Recovery Study meets the necessary PS-12B guidelines and the analyzer can be used to analyze samples that have section-one sample amounts between the high and low points that you chose.

Please note: Calibration ranges and spike values may be different based upon analyzer profile settings and expected sorbent trap field sample masses.

## Appendix G:

### Tips to Streamline Sorberent Trap Analysis using Ohio Lumex

For an experienced analyst using the Ohio Lumex sorberent trap analyzer in profile 1 (Watlow SD controller) or profiles 1 & 2 (Watlow EZ-Zone controller), calibration may take as little as 20 minutes including a blank and a second source standard once the instrument has warmed-up.

Here are some shortcuts that make the progress a bit quicker:

- **Leave Analyzer System powered on.** To avoid waiting for the furnace to warm-up at the beginning of the day, leave it powered on overnight so that it is ready to go first thing in the morning. Please note however, that it is not recommended to keep the analyzer system powered on for more than a day at a time. Leaving the analyzer powered on for an extended period of time will severely shorten the life of the mercury lamp.
- **Vacuum out the front of the furnace.** There is no reason to clean the furnace daily. Sodium Carbonate that accumulates in the furnace can be removed by pulling it through the front of the furnace with a (shop vac) vacuum cleaner (takes 10 seconds) after disconnecting the hoses from the scrubber. This can be done any time throughout the day without the need for recalibration. The furnace must be hot. This saves time compared to disassembling the furnace to remove the debris. **Please remember to reconnect the hoses!!!**
- **Use a Multipoint Calibration Curve of 3 instead of 6.** To save time during initial calibration, perform a 3-point calibration instead of a 6-point. Method 30B (section 11.1 *Analytical System Calibration*) only requires a 3-point calibration, however, using more points will yield a better calibration. For the second source standard (use 500ng) – if not pass  $\pm 10\%$  – retry. Suggested calibration points: 20ng – use 20ul of 1.0ug/ml standard, 100ng – use 100ul of 1.0ug/ml, and 1000ng – use 100ul of 10ug/ml. Second source: 500ng – use 50ul of 10ug/ml.

- **Use Glossy Printer Paper.** If you have problems with the carbon from the traps sticking to the paper you are working with, try using glossy paper or aluminum foil, which will allow the carbon to slide off easier.
- **Use Ohio Lumex Sorbent Traps.** For short term testing or low-level testing we recommend using Method 30B two section traps (part number RPM021-30B) or new PS 12B RATA- three section traps (RPM021-RATA). All of the traps mentioned have smaller carbon sections that make it easier to analyze the carbon and the foil-wrapped glass wool plug in one ladle. Using these traps can streamline the trap analysis procedure.
- **Analyze the plug and carbon separately.** If you need to analyze the larger section traps (1.0 + gram), it may be easier to analyze the carbon and the glass wool plugs separately.

## Appendix H: Tips for Successfully Using Method 30-B to Perform Mercury RATAs at Low-Level Sources (it's Easier than You Think!)

*Be careful with these recommendations and make sure that the RATA you are performing also complies with any specific state mandates.*

The new Mats Rule referenced in 40 CFR Part 60 & 63 has changed some of the criteria for a Mercury RATA as shown 4.1.2.2 “The special considerations” specified in paragraph 4.1.1.5.1 of this section apply to the RATA of a sorbent trap monitoring system. Also special consideration changes have been made to breakthrough criteria when performing a RATA on a sorbent trap sampling system as referenced below.

4.1.1.5.1 *Special Considerations*. A minimum of nine valid test runs must be performed, directly comparing the CEMS measurements to the reference method. More than nine test runs may be performed. If this option is chosen, the results from a maximum of three test runs may be rejected so long as the total number of test results used to determine the relative accuracy is greater than or equal to nine; however, all data must be reported including the rejected data. The minimum time per run is 30 minutes if the RATA is being performed against a PS 12A (Instrumental Hg CEM) or PS 12B (Sorbent Traps CEM).

A lot of frustration has been reported from crews attempting to complete mercury RATAs using method 30-B at sources where the mercury levels are low. Successfully completing one of these RATAs with minimal frustration can be achieved by focusing on strategies in 2 key areas:

- Optimizing the measurement system
- Being aware of and taking advantage of the method's built-in leniency for low-level sources

### **Method Information**

Method 30-B has actually been well crafted to deal with the challenges of low-level sources. Let's review some of the provisions of the method and how they can help with low-level measurements.

### **Low Level Standard**

One of the least understood parts of the method is the provision to allow quantification of low level samples using a one-point calibration based on a low-level standard that should be run each day analysis are performed at a level  $>$  the MDL level and  $<$  the lowest point in the Initial Calibration. This is explained in section 11.3 of the method. The response factor from this low-level standard should be used to quantify anything analyzed that produces a response less than that of the lowest point in the multi-point calibration. This includes blanks, section-2 breakthrough amounts, and most importantly, for section-1 sample amounts that are very low.

Looking at table 9-1 in the method, we see that sample analysis only have to be within the "valid calibration range" if the mercury concentration of the source is greater than or equal to 0.5 ug/dscm. We also see that section-1 sample amounts only have to be within the bounds of the Bias Test if the source is greater than or equal to 0.5 ug/dscm. In other words, according to the method, section-1 sample amounts do not have to be bracketed by the multi-point calibration or the Bias Test for sources that are  $<$  0.5 ug/dscm. This means that you don't have to make heroic efforts to successfully perform a special Bias Test or Initial Calibration at very low levels for these sources.

### **Section-2 Breakthrough and Paired Trap Relative Deviation**

Further review of table 9-1 shows that for sources where the mercury concentration is  $\leq$  1.0 ug/dscm, the limits for acceptable breakthrough and Relative Deviation for paired trap agreement double from 10% to 20%. This is a big help especially when dealing with breakthrough for section-1 amounts that are very small.

### **Field Recovery Test**

The method requires that the spike levels for the Field Recovery Test must be within 50% to 150% of the “expected” sample amount, but not the actual sample amount, and there is no penalty for falling outside these bounds. Also, since Field Recovery Test values are calculated using the average of the 3 runs ( $\pm 15\%$ ) and since the limits are 85% to 115% of the spiked value, it is not difficult to meet these requirements even at very low-level sources.

### **Relative Accuracy – HG Cems**

According to CFR 40, part 63, a RATA passes if the 30-B measurements and the HG CEMs system have a relative accuracy of  $\leq 20\%$  **or** if they agree within 1.0 ug/dscm. This is a pretty big “barn door” to hit. For low-level sources, the 2 measurement systems could differ by a factor of 10 and still pass the RATA.

The full leniency of the method comes into play below 0.5 ug/dscm. At this level, sampling at 2 L/min, 60 ng can be collected in an hour, which is a sufficiently high mass to make things work easily. Below this level the changes in the method constraints detailed above compensate for any difficulties associated with the smaller mass loadings.

### **Performing RATAs on PS 12B Systems**

The RATA criteria for a sorbent trap sampling system under the new Mats rule is in 40 CFR Part 63 sect 4.1.2 and the special considerations that apply for the RATA are shown in sect. 4.1.2.2

### **Paired Trap Relative Deviation**

PS 12B Relative Deviation limits from table 12B-1 for sources are as follows  
 $\leq 10\%$  Relative Deviation (RD) if the average concentration is  $> 1.0 \mu\text{g}/\text{m}^3$   
 $\leq 20\%$  Relative Deviation (RD) if the average concentration is  $\leq 1.0 \mu\text{g}/\text{m}^3$

This method also allows if absolute difference between concentrations from paired traps is  $\leq 0.03 \mu\text{g}/\text{m}^3$ .

### **Spike Recovery**

Similar to method 30-B, the PS 12B method says that spike levels should be matched to the “expected” sample amounts  $\pm 50\%$ , and similarly there is no penalty for failure. The PS 12B spike recovery limits are calculated on each trap but are wider than the 30-B limits at 75% to 125% of the actual spike amount. These things make it difficult to fail the spike recovery provisions of this method.

### **PS 12B Sample Amount**

Keep in mind that for PS 12B, the sample amount is defined as the sum of the section-1 and section-2 mercury masses.

### **Breakthrough**

Under the new Mats Rule 40CFR part 63 Subpart UUUUU sect 4.1.2.2 the breakthrough criteria is as shown below when performing a RATA.

### **STS RATA Criteria Section 2 breakthrough depends on stack gas Hg concentration**

The allowable breakthrough is:

$\leq 10\%$  of Section 1 mass if HG is  $> 1 \mu\text{g}/\text{m}^3$

$\leq 20\%$  of Section 1 mass if HG is  $> 0.5$  and  $\leq 1 \mu\text{g}/\text{m}^3$

$\leq 50\%$  of Section 1 mass if HG is  $> 0.1$  and  $\leq 0.5 \mu\text{g}/\text{m}^3$

There is **no breakthrough criterion** if HG is  $< 0.1 \mu\text{g}/\text{m}^3$

### **Optimizing the Measurement System for Low-Level Analysis**

While optimizing the measurement system used for 30-B analysis is always beneficial, it is crucial for success at low-level sources.

#### **Sorbent Traps**

Utilizing good quality well-designed sorbent traps can prevent many problems with breakthrough, spike recovery, the ability to collect sufficient mercury mass and other issues. It is important that the sorbent material used in the traps has a low native mercury level and it should be assured that spiked traps have been prepared using guidelines that assure that the spike levels are accurate. Using traps that can allow higher flow levels when sampling can allow the capture of a suitably high level of mercury in a shorter time. If a RATA is being done on a PS 12B system, PS 12B RATA traps should be used. These traps have less resistance and can be used at higher flow rates to make analysis easier. Ohio Lumex also makes a special sorbent trap for RATA on very low level sources called the 30B LEE which have special high flow glass and are packed to withstand up to 4 L/min flow rates. The background level on the carbon for these sorbent traps is also exceptionally low because the carbon is taken through an additional step in attempt to take as much background Hg off of the carbon as possible.

#### **Probes and Sampling Pumps**

As with the traps, low-level testing is quicker if the sampling pumps used can sample at higher flow rates. At least one company sells a booster pump that can be used in conjunction with your existing pumps if they are not up to the task. The accuracy and precision of your sampling equipment is particularly critical when sampling at these low-level sources so extra attention to maintenance and calibration is called for.

#### **Moisture**

Excessive water in the traps can cause breakthrough and poor dual-trap agreement. Moisture is best dealt with by making sure that your probe temperature is high enough

to eliminate liquid water in the trap sections. The short term sampling working range for good quality traps is quite large, up to 450° C, so it should be easy to find a temperature to prevent water in the traps. Shrouds or Trap Shields on the probe can prevent liquid water from being sucked into the traps. Moisture resistant traps are also available and can be used in situations where in-stack moisture levels are causing problems (Like after a Wet FGD).

### **Optimizing the Thermal Zeeman AA Analyzer**

For low-level sources, the analyzer like the sampling components should be in top shape and well maintained. Additionally there are a few techniques that can help with these sources.

Lowering the flow on the analyzer will increase the sensitivity and precision and make analysis of lower mercury amounts easier. You will have precise flow on the pump station down to 0.5 l/min. Make sure the cell windows are clean and all parts are in good working order. The baseline should be stable with a steady state RSD of < 1 or 2%. Make sure that the standards being used are good and run a 5 or 6-point calibration ranging from 5ng to 100ng or 300ng using proper pipetting techniques. Use the average of the response factors of your standards to determine your calibration curve. The RSD of these response factors should not be more than 5 or 6% if the analyzer is operating properly. Run a continuing calibration verification standard after each pair of traps to limit the amount of data lost if a standard fails.

### **Method Detection Limit (MDL)**

It is important to have a good MDL determination. Weighing out the amount of carbon used in each replicate can decrease precision variances due to the native mercury present in the carbon. To assure that the area for each replicate represents mercury measured and not baseline noise, you need to isolate the baseline from the peak either by manually integrating the peaks or just waiting 30 to 35 seconds before starting integration after the sample has been inserted in the oven. Standards at 3 ng are frequently used for MDL studies.

### **Sample Preparation**

When traps are analyzed, the glass can be cut after removing the section-1 materials so that the section-2 materials can be removed without dragging them through any debris that may be in the front half of the glass tube. This can help avoid false high breakthrough readings.

### **30-B is the Reference Method**

Keep in mind when performing RATAs against CEMMs that below a certain level the CEMM will not be able to measure as accurately as the sorberent traps. Even if the data passes, the numbers might not match. Remember, 30-B is the reference method and if all is working properly, the CEMM must match the 30-B results and not the other way around.

### **Summary of Low-Level Techniques-Method**

- Samples from Sources  $< 0.5$  ug/dscm don't have to be within the bounds of the Initial Calibration or the Bias Test
- Calculate Low-Level Samples with the Low-Level Standard
- The Breakthrough Limit Increases based on the concentration of the source (See STS RATA Criteria)
- The Limit for Relative Deviation for Paired Traps Increases from 10% to 20% for sources that are  $\leq 1.0$  ug/dscm
- Spike Levels are Based on "Expected" Sample amounts, no Penalty for Failing
- Field Recovery is Calculated using the Average of the 3 Runs
- CFR-40 Only Requires Agreement Within 1.0 ug/dscm

**Summary of Low-Level Techniques – PS 12B**

- Sources  $\leq 1.0$  ug/dscm are allowed up to 20% Relative Deviation Between Paired Traps (or  $\leq 0.03$  ug/dscm maximum variance)
- Spike Levels Should be 50% to 150% of “Expected” Sample Amount, No Penalty for Missing
- Spike Recovery must be a Generous 75% to 125%
- Sample Amount = Section-1 plus Section-2

**Summary of Low-Level Techniques-Measurement Optimization****Use Good Quality Traps**

- Low Native Mercury
- Accurately Spiked
- Amenable to Higher Flow Rates
- Use PS 12B RATA Traps for PS 12B Systems

**Sampling Equipment**

- Use Sampling Pumps that can Accommodate Higher Flow Rates or a Booster Pump
- Ensure Sampling System is In Good Repair

**Moisture**

- Use Sufficient Probe Temperature
- Use Moisture Resistant Traps
- Probe Shrouds or Trap Shields

**Thermal Zeeman AA Analyzer Optimization**

- In Good Repair

- Use Lowest Flow (down to 0.5 L/min)
- Make Sure Cell Windows are Clean
- Assure that Baseline RSD is less than 1-2%
- Use Good Standards
- Use a 5 or 6 Point Calibration, 5ng to 100ng or 300ng
- Use Average RF Calibration Calculation
- Assure that the RSD of the Calibration RFs is < 5-6%
- Don't Forget to Run the Low-Level Standard
- Analyze a C CVS after each Pair of Traps
- Have a Good MDL Determination
- Cut Traps if Needed to Remove Section 1 & 2

### **In Summary**

Using Method 30-B to perform mercury RATAs at low-level sources will continue to be somewhat more challenging than those at other sources. For a power plant, this is a good thing because the ultimate goal will be low mercury emissions. Hopefully, this information on system optimization and the details of the methods will make performing RATAs on even very low-level mercury sources easier.

## Appendix I: Method 30B Spiked Sample Calculations

Method 30B requires that 3 runs be conducted where one of the paired traps is spiked with a known quantity of mercury on section 1. These runs are used as the “Field Recovery Test” to demonstrate a suitable recovery for the spiked mercury. These 3 runs can also be used as 3 of the RATA runs if the Relative Deviation of the 2 paired traps is sufficient when the spike amount is subtracted from the spiked trap (and other requirements are met).

Here is an example demonstrating how these results might be calculated in a real world environment:

- Suppose for one run of the Field Recovery Test the following data was collected: Trap A was unspiked, collected 14 dry standard liters of sample and upon analysis was found to contain 58ng of mercury. Trap B was initially spiked at 60ng collected 15.5 dry standard liters of sample and upon analysis was found to contain 126ng of mercury.

- First we will calculate the spike recovery for the spiked trap. The first step will be to calculate the mercury concentration of the sample gas as indicated by the unspiked trap. This will be  $58\text{ng}/14 \text{ Liters} = 4.14\text{ng/L} = 4.14\mu\text{g/dscm}$  (dry standard cubic meters)
- Next we need to subtract an amount from the spiked trap that was due to the gas sample that was deposited on it so we can see what’s left and compare that to the amount that was spiked on to it.

15.5 Liters of sample were placed onto the spiked trap. From the above calculation we know that each liter of this gas should contain 4.14ng of mercury, for a total of 64.2ng. Subtracting this 64.2ng from the total of 126ng we get 61.8ng. This is the 61.8ng remaining that is due to the 60ng of mercury that was spiked on the trap initially. So, the spike recovery is:  $61.8\text{ng}/60\text{ng} \times 100\% = 103\%$ . If the average recovery of the 3 spiked runs is within 15%, the field recovery test has passed.

- Now, we can see if this example used above can also be used as a valid RATA run.

For the unspiked trap, Trap A, we know from the calculations above that the mercury concentration of the sample was 4.14µg/dscm. For Trap B we can calculate the sample concentration once we subtract out the amount of mercury that was spiked onto the trap. So, 126ng minus the 60ng that was spiked onto the trap equals 66ng. This 66ng is the mercury from the 15.5 Liters of sample that passed through the trap. So the indicated concentration from this data is 66ng per 15.5 Liters (66ng/15.5 L) = 4.25ng/L = 4.25 µg/dscm.

The Percent Relative Deviation of the 2 traps is 100% times the absolute value of the difference between the 2 concentrations divided by the sum of the 2 concentrations, or  $100\% \times (4.25\mu\text{g/dscm} - 4.14 \text{ dscm}) / (4.25 \mu\text{g/dscm} + 4.14\mu\text{g/dscm}) = 100\% \times (0.11) / (8.39) = 100\% \times (0.013) = 1.31\%$ .

For sources with mercury concentrations > 1µg/dscm, the maximum allowable Relative Deviation between the 2 traps is 10%, so in this case, with the Relative Deviation at 1.31%, this run easily meets the requirement for a good RATA run as far as Relative Deviation is concerned. For sources with mercury concentrations less than or equal to 1.0µg/dscm, the maximum allowable Relative Deviation between the 2 traps is 20%.

## Appendix J:

### SOP to calculate R squared per PS 12B and Method 30B requirements

After you finish the multipoint calibration and save the date:

1. Export to Excel and open Excel file.
2. Separate (cut and paste) Calibration Standards Data and Area Data in two columns next to each other. Note the data must be a numerical value – delete the Std\_\_ part for the standard part of the data.
3. Select both columns and “click” on Chart Wizard.
4. Select XY scatter and chart sub-type – “Scatter with data points connected by smooth lines”.
5. Click Finish.
6. On the graph, position mouse on the line and right click.
7. Select “Add Trendline”, go to Options and check “Display R squared on chart”.

## Appendix K: Troubleshooting Sorberent Traps in case of Breakthrough and/or Spike Loss

The following is a synopsis of knowledge in Troubleshooting Appendix K Stack Sampling in case of spike loss, breakthrough, and ‘wet’ or ‘hard’ carbon:

### For “Wet” stack (After Scrubber) Sampling:

There is a problem if traps are coming back with “wet” carbon in the tube after sampling. This is a major cause of Breakthrough, Spike loss, Problems with flow, and hard “plugging” of the traps.

To troubleshoot these problems please do the following:

- a) Please use shroud which extends at least 5” inches over the end of the trap.
- b) Do not tilt probe with trap side down when removing it from the stack for trap changeovers. Condensate accumulated in the lines may leak back towards trap and upon contact with trap/heated lines turn into steam causing “steam stripping” of mercury from the back of the trap (spiked section) toward the front-into breakthrough section.
- c) Post run “leak check” vacuum should NOT be released through the trap cap, but rather from the after trap connection (umbilical to probe). This will prevent a surge of line condensate back into the trap.
- d) Test each trap well temperature with an independent handheld thermocouple thermometer by inserting it into each trap holder for the length of the trap. Compare the handheld reading and units (F or C) with setting on the sampling console “Trap” (not “Probe” or “Stack”) temperature.
- e) Exposing the traps to high temperatures may lead to Spike Loss. In general, the trap temperature for a “wet” stack should be higher than the stack to prevent condensation. However, elevated temperature is bad for spike retention. The best range is 260-350°F and is unique for each stack due to its conditions. Test

the temperature as described in D), confirm that the trap well temperatures are correct, and only after that start decreasing the temperature in 50°F intervals.

- f) We have incredibly strenuous QAQC procedures making spiking absolutely error-proof. Therefore, it is very unlikely that the spike is wrong. In case of doubt, send a couple of unexposed traps back to Ohio Lumex for testing. You will be credited for the shipping and the traps. If we ever find a problem we will credit your account and replace all of the traps free of charge.
- g) Consider switching to the High Moisture Resistant extended length Sorbent Traps. We custom make these sorbent traps for “wet” source clients.

### **Dry Stack with Urea or Anhydrous Ammonia Spray**

- a) If traps are coming back with “hard” carbon or the loss of flow/vacuum is too “high,” increase the temperature gradually up to 350°F.
- b) Loss of Spike might still be an issue. At “dry” stacks the temperature could be just 25°F elevated above the stack temperature. Decrease the temperature in 25°F intervals.
- c) After the trap condensation may still be a problem. Practice technique described in section 1 (c and d).

### **Stacks with High SO<sub>2</sub> and SO<sub>3</sub>**

- a) High SO<sub>2</sub> and SO<sub>3</sub> concentrations in the stack gas have a drastic effect on mercury. They basically fight for space against mercury on the activated carbon by filling up the active sites on the carbon. The Acid Gases wind up forcing the mercury to pass through the trap or displacing the mercury. They have a tendency to lead to extreme breakthrough and spike loss.
- b) With these conditions please be wary of the temperatures the traps are exposed to. This means please follow the technique described in section 1 (c and d).
- c) Also, consider using sorbent traps with an Acid Gas Scrubber before the first section of sorbent. This will scrub the Acid Gases out of the flue gas and allow mercury to deposit on the first Activated Carbon bed.



9263 Ravenna Rd., Suite A-3  
Twinsburg, OH, 44087  
Toll Free: 888-876-2611

## **APPENDIX L: SPECIATION TRAP ANALYSIS PROCEDURE**

Subject  
Mercury Emissions Monitoring Program  
Speciation Sorbent Trap Analysis

Prepared by Analytical Laboratory of Ohio Lumex Company

Revised on January 21<sup>st</sup>, 2013

## **FGD INLET/AFTER ESP, SCR, NSCR, or “DRY” STACK LOCATION:**

Traps should be sampled directly in the stack and not externally.

**TEMPERATURE:** The recommended trap temperature range for Speciation traps is between 220°F and 300°F. A cooling probe is only needed if you experience breakthroughs after 30 minutes of sampling (high SO<sub>2</sub> >1000ppm and/or SO<sub>3</sub> > 30ppm concentration) or if the flue gas temperature exceeds 350°F.

**FLOW RATE:** The recommended flow rate for Speciation traps is between 200cc/min and 250cc/min.

**SAMPLE VOLUME:** The recommended sample volume is close to 20L (depending on the source concentration.) This will provide sufficient mercury capture that can be easily distinguished from background levels and make analysis easy to perform.

**STARTING PUMPS:** The standard leak check procedure should be done and documented. The sampling pumps should be started before the probe is inserted into the duct. This is extremely important if there is positive pressure at the sample location or if you are using a mass flow controller to control the flow as it will prevent initial direct particulate entrainment on the front plug.

**SHROUD:** A shroud of 6 to 12 inches in length **MUST** be used to prevent particulate from entering the trap during the test run. Please use thin aluminum (available as roofing material in Home Depot) and a clamp to hold it to the end of the probe.

## **WET STACK LOCATION (AFTER FGD):**

Traps should be sampled directly in the stack and not externally.

**TEMPERATURE:** The 4-8 inches before the first section on the trap must be heated inside of the probe to at least 230°F and must not exceed 300°F. This will ensure that any moisture remains in the vapor phase as it passes through the trap. It is also important to make sure the probe is fully heated before it is inserted into the stack.

FLOW RATE: The recommended flow rate is between 200cc/min and 250cc/min.

SAMPLE VOLUME: The recommended sample volume is approximately 20L (depending on the source concentration.) This will provide sufficient mercury capture that can be easily distinguished from background levels and make analysis easy to perform.

STARTING PUMPS: The pump should be started before the probe is inserted into the stack.

SHROUD: A shroud of 6 to 12 inches in length **MUST** be used to prevent direct moisture entrainment during the test run.

### **ADDITIONAL NOTES:**

For inlet or dry stack locations, the shroud used must be made from a material that will not be affected by the high temperatures of the flue gas (as described above). The shroud used in a wet stack location can be made out of plastic tube or metal.

The distribution of oxidized mercury over the AGS and KCl sections is dependent upon many factors, but it is important to know that the plugs will capture oxidized mercury. The bond that is created between these sections and the oxidized mercury is a very weak physical bond and too much temperature or flow will cause these bonds to fail and result in breakthrough.

For both locations the front plug must have minimum amount of particulate or discoloration from white color.

Please note: Large amount of particulate or moisture on the front plug will skew the Total and speciation ratio and make the run invalid.

*We have found that the aforementioned sampling procedures will yield the most consistent and reproducible results.*

## 1 SPECIATION TRAP ANALYSIS PROCEDURE RECOMMENDATIONS

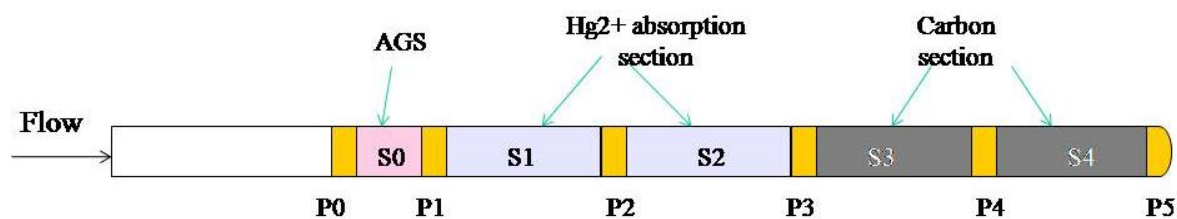

S0 = Acid Gas Scrubber (AGS)

S1 = Oxidized Mercury Analytical Bed (KCl)

S2 = Oxidized Mercury Breakthrough Bed (KCl)

S3 = Elemental Mercury Analytical Bed (Carbon)

S4 = Elemental Mercury Analytical Bed (Carbon)

Figure 1. Illustration of a Speciation Trap

*For full analytical procedure, please refer to the Speciation Traps Analytical SOP.*

1. Clean the furnace and analyzer windows before heating up the furnace. Calibrate analyzer as per method 30B using carbon as calibration substrate. Change temperature set point on Watlow controller (use up/down arrow keys) to 590°C. The furnace must look almost dark if looking inside through the ladle entry hole. Only one calibration curve is required for the analysis of AGS, KCl, and carbon. **Cover all sections with soda except for the AGS section.** Soda must be pressed using a sheet of Aluminum Foil. **Never place KCL on top of carbon.** Use upgraded pump station and set flow rate to 0.5 Lpm. Use low level calibration from 2ng to 20 ng and use averaged calibration coefficient in calculations.

2. Please “burn off” ladles before you proceed with analysis. After heating in the furnace, let the ladle cool before cleaning off the residue. Remove sticking residue by gently scraping the ladle or washing it in water. Melting or fusing of the KCL with soda indicates overheating so you must drop the temperature on the controller 10 or 20 degrees. Wash ladle with water at the end of the day of testing. **Use ceramic ladles.**
3. Average analysis time is 180-220 seconds. Wait for KCL peak to come back to baseline (it will “tail”!). Extended analysis time in the furnace (over 300 sec) indicates that the temperature is too low. Manually integrate the peaks to ensure only the captured sampled mercury is accounted for (not the baseline noise).
4. Do not pull the glass wool through the trap (ash bonded mercury will bias the results.) Cut the traps with a dremel fitted with a diamond wheel blade right before the front plug.
5. Wrap the plug wool in aluminum foil before ladle goes in the furnace and wear rubber gloves to ensure there is no additional mercury transferred to the plugs. Test the foil for mercury adsorbed from air and discard if positive. Test the carbon used in calibration. Do not leave carbon open to lab air for long time.
6. You may combine first and second wool plugs (P0, P1) to save on analysis time. You may analyze section 0 (acid gas scrubber) and section 1 (1<sup>st</sup> bed of KCL) together. P2 and section 2 must be analyzed separately to determine if breakthrough is present.
7. The remaining carbon sections are to be analyzed just like a 30B sorbent trap.
8. Oxidized mercury is equal to the loading on section 0 (acid gas scrubber), section 1 (KCL), and section 2 (KCL breakthrough) as well as (P0, P1, P2) combined. If breakthrough is experienced, sampling conditions must be altered to prevent this from happening again. Elemental mercury is equal to the loading on section 3 and section 4 as well as (P3, P4, P5) combined.

9. Try not to spill soda in the oven. Clean oven (when still hot) at the end of the day with vacuum cleaner nozzle approaching from the ladle intake port. Disconnect silicone lines (before filter) to provide unrestricted flow back through the Furnace. Connect lines back.

## 2 INTRODUCTION TO THE ANALYSIS METHOD WITH RA-915+/RP-M324 MERCURY ANALYZER

This document describes the procedure of sorbent trap analysis using the Ohio Lumex RA915 + with the RP-M324 attachment for total mercury (**Hg**) determination by thermal decomposition with atomic absorption and Zeeman Correction.

The analytical method at Ohio Lumex is based on the thermal desorption per EPA Method 7473 (direct thermal desorption with atomic absorption and no gold amalgamation). The method is applicable for total mercury “direct” testing of 40 CFR Part 75 Appendix K, EPA Method 30B sorbent traps, and speciated mercury measurement sorbent traps. The reporting limit (RL) is equal to the method detection limit (MDL) determined for the instrument of total mercury testing.

Analysis time depends on the type of controller used and the selected profile. Typically, the run time is about 90 seconds per sample.

The required instrument and accessories for performing the analysis include,

- Ohio Lumex- RA 915+ with RP-M324 Attachment;
- Computer;
- Ohio Lumex 6 inch ladles;
- Assorted laboratory equipment, which includes spatulas, glass wool extractor, tweezers, adjustable pipettes, aluminum weigh boats, aluminum foil, torch, trap cutter and so on.

Reagents and standards include,

- NIST-certified and NIST- traceable mercury calibration standards;
- Second source NIST standard;
- Sodium Carbonate;
- Calibration sorberent media.

Although the Zeeman correction used by the Ohio Lumex analyzer eliminates spectral interferences in the analyzer, halogens and especially iodine and chlorine will form acid gases in the furnace. These acid gases will react with the elemental mercury and plate out mercury salts on the optical lenses in the analytical chamber. Therefore, granular sodium carbonate is ALWAYS placed on top of the sorberent media to capture the acid gas and eliminate the acid gas interferences.

Calibration substrate is the same media in the sorberent trap. If a different substrate is used as the calibration purpose, calibration adaptability to the different media must be demonstrated before analyzing any trap.

### 3 ANALYTICAL PROCEDURE DETAILS

The sorberent trap tube end cap is removed. The empty tube before the first plug is cut down by the trap cutter blade. Using the tweezers or extractor, the glass wool plug at the front of the appropriate sorberent bed is carefully removed and separated from the sorberent fraction. The sorberent is transferred into a quartz ladle and then covered with anhydrous sodium carbonate. The ladle is inserted into the analyzer thermo catalytic conversion chamber. As a result, elemental mercury ( $\text{Hg}^0$ ) is liberated into the gas stream and oxidized mercury ( $\text{Hg}^{2+}$ ) is converted from a bound status to the atomic status by thermal decomposition in the furnace and is then detected by atomic absorption with Zeeman correction. The mercury concentration is measured and recorded using an automated data collection system. Both the glass wool plug and the sorberent of each section are analyzed and the final Hg mass is figured by adding the measurements together.

The procedure for the trap analysis is described here step by step,

- 3.1 Instrument start-up
- 3.2 Preliminary determination of mercury mass in the traps,
- 3.3 Analyzer calibration;
- 3.4 Trap analysis;
- 3.5 Verification of calibration during testing and post-calibration;
- 3.6 Data saving and results reporting.

### 3.1 Instrument Start-up

3.1.1 Set up the connections among RA-915+ analyzer, RP-M324 attachments and laptop computer. Analyzer setup with new EZ-Zone controller is shown in Figure 1, with SD controller in Figure 2.

3.1.2 Connect power cord to RA-915+, RP-M324 and laptop computer.

3.1.3 Complete setup with heat shield.

3.1.4 Turn on computer.

3.1.5 Turn on RA-915+ power toggle switch and ignite mercury lamp by pressing and holding lamp ignition button for 1-5 seconds.

3.1.6 Turn on the RP-M324 power supply. Warm up the analyzer and choose a proper profile to run. The carrier pump flow rate is now bounded to the profiles for the new RP-M324 power supply system with EZ-Zone controller. When the profile is selected, the pump will automatically adjust to the desired flow rate. However, for the SD series controllers, flow setting is manual.

The profiles and their setting information for an EZ-Zone controller and a SD controller are listed in Table 1 and Table 2.

**3.1.7** Start the RA-915 software from the Windows main screen by double click

the icon . The RA-915+ Main menu screen will appear.



Figure 1. Analyzer setup with an EZ-Zone controller

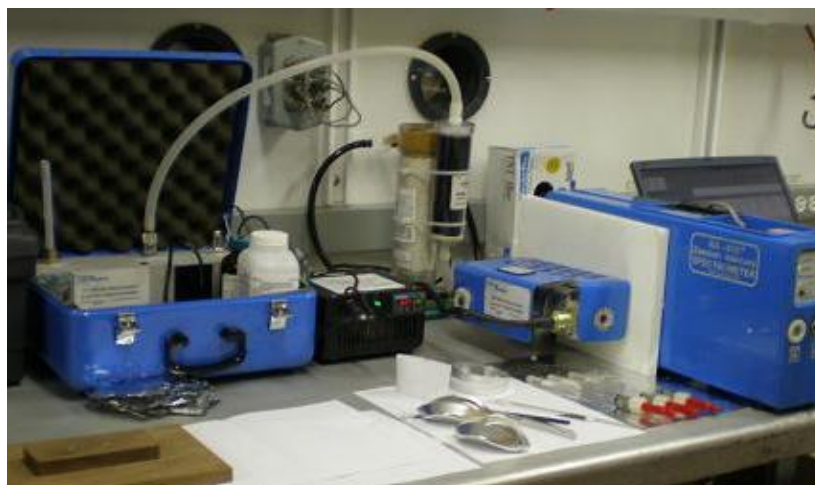



Figure 2. Analyzer setup with a SD controller

**3.1.8** Select “Complex” on RA-915+’s main menu screen, a table window (“Table. Complex analysis”) and a graph window (“Complex Sample analysis Graph”)



both activate. Click on the window headers to alternate between the two screens.

**3.1.9** Click the “run” icon  from graph window. Mercury signal will begin to be recorded with a sampling frequency of 1 second. Expand the “Current Value” window to see the second by second readings which are also graphed as the red line.

**3.1.10** Enter information in table window. Name and Save the table file into a specified folder.

**3.1.11** Allow the system to warm up for at least 30 minutes before calibration.

**3.1.12** Click the statistics icon  to view the average baseline value and the baseline RSD. After 20 minutes, if the RSD is higher than 5, shut off the furnace, allow it to cool down, and clean the optical detector windows.

**3.1.13** Click the icon  (baseline check) and allow the baseline to adjust for 10 seconds. Click on  again, to turn off the baseline adjustment and complete the baseline correction. Repeat this step until the average baseline is near zero and the RSD is less than 4. After the initial start-up of the instrument, baseline drift will be at its maximum and diminish with warm-up.

## 3.2 Preliminary Determination of Mercury Mass

The expected mercury mass is an estimate of the total mercury collected in section 1 of a sorbent trap. The estimation for this amount is very important to decide the calibration range and choose a profile.

Knowledge of estimated stack mercury concentrations and total sample volume may be required prior to analysis. Information may be received from the stack testers. However, an analyst should always evaluate the traps based on the information shown in the

“Chain of Custody”, i.e. the sampling duration, flow rate, dust temperature, meter temperature, dry gas volume, and pre-spiked Hg-mass. A proper testing profile can be chosen after the evaluation. Table 1 shows the most current profiles at Ohio Lumex new M324 attachment system with an EZ-Zone Controller. Table 2 lists profiles and their settings for M324 attachment system with a SD-controller.

Table 1. Profiles and Settings of an EZ-Zone Controller

<b>Profiles</b>	<b>Starting Temp.</b> (°C)	<b>Flow Rate</b> (L/min.)	<b>Test Range</b> (ng)	<b>Duration</b> (sec.)
<b>1</b>	680	0.5-2.0	1-1,000	100
<b>2</b>	652	4.0	10-2,000	120
<b>3</b>	653	4.0	10-20,000	350
<b>4</b>	654	4.0	10-50,000	700

Table 2. Profiles and Settings of a SD-Controller

<b>Profiles</b>	<b>Starting Temp.</b> (°C)	<b>Flow Rate</b> (L/min.)	<b>Test Range</b> (ng)	<b>Duration</b> (sec.)
<b>1</b>	680	4.0	1-2,000	100
<b>2</b>	460	4.0	100-20,000	500
<b>3</b>	380	4.0	500-50,000	750
<b>4</b>	360	4.0	500-100,000	1000

### 3.3 Analyzer Calibration

A certified analyzer is used to test sorbent traps. The analyzer certificate provides the information on Method Detection Limitation (MDL), bias and spike recovery study results. MDL is the minimum amount of the analyte that can be detected and reported. It is statistically derived from replicate low level measurements near the analytical instrument's detection level. The bias test demonstrates the analyzer's ability to recover and accurately quantify  $Hg^0$  and  $HgCl_2$  from sorbent media. The bias test is performed at a minimum of two distinct sorbent trap Hg loadings that represent the lower and upper bound of sample Hg loadings from application. Spike recovery study is required by Appendix K to Part 75. It shows the ability of laboratory to recover and quantify Hg from sorbent media traps spiked with elemental mercury. The analyzer certificate is available upon customer request.

It is important to clean ladles and tools before testing any standards or samples. Mercury deposited on the ladle would influence the calibration and testing. By inserting an empty ladle into a heated furnace (Temperature  $>500^{\circ}C$ ) for at least 90 seconds, any potential mercury contamination on the ladle will be removed. The glass wool extractor and tweezers should be cleaned by a 5-seconds torch burning. Calibration sorbent media must be stored in a sealed container. Any media exposed to air for more than 5 hours should not be used for calibration purposes.

Only National Institute of Standards and Technology (NIST) certified or NIST traceable calibration standards and standard reference materials shall be used for the analytical procedures. The entire set of Ohio Lumex calibration standards consists of 0.01  $\mu g/ml$ , 0.1  $\mu g/ml$ , 1.0  $\mu g/ml$ , 10.0  $\mu g/ml$ , 100.0  $\mu g/ml$ , 1000.0  $\mu g/ml$  and second source of 0.1  $\mu g/ml$ , 1.0  $\mu g/ml$ , 10.0  $\mu g/ml$ , 100.0  $\mu g/ml$   $Hg^{2+}$  solution. Depending on the calibration range, not all standards are needed to make a calibration. However, to avoid misleading a calibration due to bad standards, at least 3 standards are required to use for making any calibration. The expiration date of a standard must always be checked before a calibration is run. Manufacturer concurs with state and federal regulatory agencies'

recommendations that solution standards be assigned a one-year expiration date. The expiration date is printed in the document of standard certification.

### 3.3.1 Calibration procedure

- 1) In the “Table. Complex sample analysis” window enter the appropriate testing description information (For example, sample type, analysis date, etc) into the top box just below the menu icons on the table window. Save table.
- 2) Check the RSD and baseline. The baseline can be slightly positive or negative. The current value window shows the mercury intensity for each second. Zero the baseline for 10 seconds if necessary. At a static state, RSD should be a stable value.
- 3) **BLANK**: Place cursor in description column (second column) beside No 1. Double click left mouse and select BLANK. Using the tab button on the keyboard tab to the mass column (third column) labeled “M, mg”, enter number 1 into the box, then tab over to the concentration column labeled “C, ng/g”.
- 4) Switch back to the “Complex analysis graph” to view the graph of analysis.
- 5) Place calibration sorbent into a ladle, (about 0.4g sorbent when Method 30B speciation traps are going to be tested). Cover the sorbent with anhydrous sodium carbonate. Gently pack the sorbent and sodium carbonate in the ladle by covering the opening with a piece of aluminum foil and compressing the solids through the foil with your finger. Sodium carbonate must completely cover the sorbent. Remove the aluminum foil from the ladle before analysis.
- 6) Click **START** on the integration window. Immediately insert the prepared ladle into the furnace.
- 7) Mercury signal is shown as red in the graph. The reading of the current value is shown in a separately small window.



- 8) Click **END** on the integration window to stop the analysis once the current value readings come back to the original starting point, and the RSD reading value is around the originally static value. The run time for the blank test is about 90 seconds as measured by the elapsed time.
- 9) Remove the ladle from the furnace, wait until cool down, then dispose contents into a heat-resistant (metal) tray, put the ladle on a heat-resistant surface before reloading it. The integration area and maximum peak height will be displayed in the "Integration" window. These values will also be automatically entered into the appropriate columns in the Table.
- 10 ) **CALIBRATION:** Switch to the "Table. Complex analysis" window. Place the cursor in the description column (second column) beside No 2. Double left click mouse and select **STD\_**. Type in the standard Hg mass (in ng) after the dual underscore, for example STD\_\_10. Check the mass column (M, mg). There should always be a "1" entered there. Tab the cursor to the concentration column (C, ng/g).
- 11) Switch back to the "Complex analysis graph" (click on it) to view the analysis.
- 12) Load the ladle as in Step 5 above. Pipette the desired volume of the appropriate standard onto the sorbent (For example, 10  $\mu$ l of 10  $\mu$ g/ml standard equals 100 ng mercury, enter 100 after STD\_\_).
- 13) Cover the spiked sorbent with anhydrous sodium carbonate. Gently pack the sorbent and carbonate in the ladle using aluminum foil.

- 14) Check the RSD and baseline. The baseline can be slightly positive or negative. Adjust the baseline for 10 seconds (clicking on Baseline check and click again to terminate in 10 seconds) if necessary.
- 15) Click **START** on the integration window. Immediately insert the prepared ladle loaded with sorbent, spiked standard, and sodium carbonate into the furnace.
- 16) Allow the peak (mercury signal) to develop until it returns to the baseline.
- 17) When the peak has returned to the baseline ("0.0"), click **END** on integration window to stop the integration. Remove the ladle from the furnace, cool it before disposing the waste, then place the ladle on a heat resistant surface. The value of integration area and maximum peak height will be automatically entered into the appropriate columns in the Table.
- 18) Repeat the step 12 to 17, until all of the planned standards have been analyzed.
- 19) To perform the calibration, there are two options to be chosen.

### Option 1:

RA-915+ analyzer come with manufacture calibration software. By running the software, calibration coefficient, square of the linear correlation coefficient  $R^2$ , and the calibration curve will show up on a pop-up calibration window. The detail on how to run the calibration is described below,

- a) Return to the "Table. Complex analysis" window. Under the Table heading,

click the **SELECT** icon,  (or from the Table pull down menu). Highlight all of the Standard rows using the Shift and Arrows on the keyboard. After the standards have been highlighted, click on the **CALIBRATE** icon, , under the Calibrate heading. A calibration graph will appear and the new calibration

coefficient will be listed as 'A'. Click on the apply icon ✓ then click on the **EXIT** icon,



. A pop up window will ask you to save the calibration coefficients. Click **YES**.

b) While the standards are still highlighted in the “Table Complex analysis

window” Click on the **CALCULATE** icon, , under the Table heading. The program will fill in the calculated values of the standards based on the current calibration. The calibration coefficient (A) and the intercept (Co) will be found at the upper right corner of the “Table Complex analysis window” .

c) Save the data in the Table by clicking on the **SAVE** icon, , under the File header or use “Save as” in the file pull-down menu. Create a folder for saving the data. Do not save files in the RA915P directory.

### Option 2:

Another option to do the calibration is to use Ohio Lumex Company calibration software, 'MINICAL915'. In this software, by entering the corresponding area count number of each tested standard into an 'Excel' table, a calibration curve, calibration coefficient (A), square of the linear correlation coefficient  $R^2$ , calculated mercury mass of each loaded standard, standard deviation % RSD, and recovery percentage will display automatically. The mercury mass for each tested sample is calculated by multiply 'A' and each corresponding area count. Detailed instruction is with the software “MINICAL915”.

### 3.3.2 Calibration criteria

Multipoint calibration is required. Three or more standards should be used to make a calibration curve. An independent standard, for example a NIST solid standard or an NIST traceable mercury standards from a separate lot, will be analyzed to ensure the accuracy of the calibration.

The calibration criteria is,

- 1) Calibrations must be performed on the day of the analysis, before analyzing any of the samples;
- 2) Three or more upscale calibration points must be used;
- 3) The lowest point in the calibration curve must be at least 5, and preferably 10 times the MDL.
- 4) The field samples analyzed must fall within a calibrated, quantitative range and meet the performance criteria of Method 30B or Appendix K;
- 5) For each calibration curve, the value of the square of the linear correlation coefficient, i.e. ,  $R^2$  , must be  $\geq 0.99$ , and the analyzer response must be within  $\pm 10\%$  of the reference value at each upscale calibration point;
- 6) Following calibration, a second source standard is analyzed. The measured value of the independently prepared standard must be within  $\pm 10\%$  of the expected value;
- 7) The analysis of blanks is optional, yet they cannot be used in the calibration.

The **Hg** amount in each sample must fall into the calibrated range of the analyzer, and within the lower and upper mass limits established during the initial **Hg<sup>0</sup>** and **HgCl<sub>2</sub>** analytical bias test. For extra low-level samples (**Hg** mass is below the lowest point in the calibration curve and above the MDL), a response factor (e.g. area count per **Hg** mass) is established based on a single standard at level > MDL and less than the lowest point in the calibration. The amount of **Hg** present in the sample is calculated based on the analytical response and this response factor.

### 3.4 Preparation of Sorbent Traps for Analyzing and Analysis Procedures

The end cap of a sorbent trap is removed; the glass wool plug prior to the appropriate carbon bed is carefully removed and separated from the sorbent section. The sorbent is transferred into a quartz ladle, and then covered with anhydrous sodium carbonate until the ladle is full. Cover the ladle opening with a piece of aluminum foil and finger press the materials in the ladle. Make sure the sodium is on the top of the sorbent and be pressed very tightly. The ladle is then inserted into the M-324 thermo catalytic conversion chamber. The glass wool plug is tightly wrapped into aluminum foil. Depending on the spare space in the ladle, the plug can be tested with sorbent together or tested individually. For a speciation trap (5 sections), the plug prior to the sorbent section is usually tested together with the sorbent in one ladle. Description and analysis procedure for Ohio Lumex speciation traps are described here:

#### (1) Speciation trap

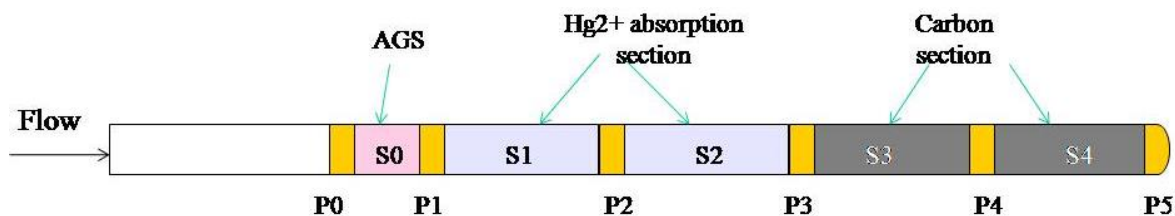

S0 = Acid Gas Scrubber (AGS)

S1 = Oxidized Mercury Analytical Bed (KCl)

S2 = Oxidized Mercury Breakthrough Bed (KCl)

S3 = Elemental Mercury Analytical Bed (Carbon)

S4 = Elemental Mercury Analytical Bed (Carbon)

Figure 3. Illustration of a speciation trap

The speciation trap is a 5 sections trap. The first section is called the AGS section, followed by two oxidized-mercury absorption sections and two carbon sections. As shown in Figure 7. The first 3 sections will be analyzed at temperature 580°C, while the rest 2 sections will be performed at regular profile 1 temperature, i.e. 680°C.

The operation procedure is described below,

- 1) Warm up the oven to 580°C, set up the flow to 2L/min. Let system stabilize until no baseline drifting and RSD value is stable.
  
- 2) Perform calibration.
  - Pull carbon into ladle, load Hg standard on carbon bed, cover the bed with Sodium Carbonate, use aluminum foil to press the material tightly.
  - Press the **START** button, insert the ladle into the oven, watch the Hg release process.
  - Press the **END** when no more Hg come out and RSD value comes back to initial value. Each run takes about 200 seconds.
  - Take a few Hg Standard tests, for example, 5 ng, 10ng, 20ng, 50ng....Calibrate the system, and check the calibration by loading a second standard.
  - Pull some Potassium Chloride into a ladle, load a Hg standard on it. Make sure the Hg mass is within the above calibration range. Cover the materials with sodium carbonate and finger press them tightly through a piece of aluminum foil.
  - Insert the ladle into the oven, and test it. The Hg recovered from this test should be with  $\pm 10\%$  of the original loading. Otherwise, troubleshoot the system.
  
- 3) Test the trap AGS section (section 0), and first 2 oxidized-mercury absorption sections (section 1 and 2).

- 4) Cap the remaining trap (section 3 and 4), label it clearly and leave it away for a later test.
- 5) Take the other speciation trap, repeat step 3 and step 4 until all traps are finished. Do standard verification.
- 6) Bring the oven temperature to 680°C, calibrate profile 1.
- 7) Test the remaining parts of each trap (section 3 and section 4) under profile 1 condition.
- 8) Do standard verification at the end. Save file and report the results.

The analysis procedure is shown in Figure 4.

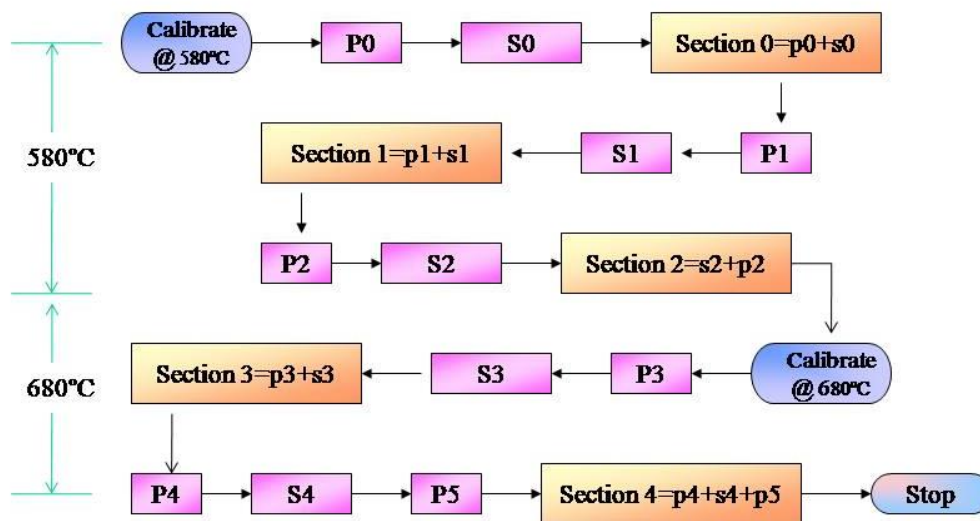

Figure 4. Analysis of a Speciation Trap

**!! Analysis Tip:**

*Be VERY careful when analyzing speciation traps. It is imperative to keep the Potassium Chloride and Sodium Carbonate separate. Sodium Carbonate is used to cover every sample before entering it into the oven. Since the two look similar, label the dishes accordingly, so that Potassium Chloride is not mistaken for Sodium Carbonate when performing analysis.*

When a speciation trap is analyzed, please ALWAYS remember, the temperature needs to be down to 580°C for analyzing the first 3 non-carbon sections.

**3.5 Calibration Verification****3.5.1 Analysis of continuing calibration verification standard (CCVS).**

After no more than 10 analyses, a continuing calibration-verification standard must be analyzed. The standard should fall into the calibration range. The measured value of the CCVS must be within  $\pm 10\%$  of the expected value.

**3.5.2 Post-calibration verification**

At the end of each set of analysis, a calibration standard will be tested. The standard should be within the calibration range and the measured value of this standard must be with  $\pm 10\%$  of the expected value.

**3.6 Data Saving and Reporting**

At the end of testing, all data should be saved in the Ohio Lumex database. Data can be reported as an Excel file, (\*.xls), pdf file (\*.pdf) or in a report format (\*.qrp). Customer can request an extended laboratory report from the Laboratory.

An extended lab report includes the following,

- 6) Analyzer certificate;
- 7) Mercury standards certificates;

- 8) A formal report, showing all standards and traps testing time, sequence and corresponding results;
- 9) Pre-calibration report;
- 10) Post-calibration verification report.

#### 4 TERMS AND DEFINITIONS

AGS	Acid Gas Scrubber
Appendix K	quality assurance and operating procedures, published by US EPA for sorber trap monitoring systems
Blank-	Any raw carbon sample not spiked with liquid mercury solution or elemental mercury gas.
Calibration Standards-	NIST certified or traceable mercury standards used to determine an instrument calibration.
CCVS	Continuing Calibration Verification Standard
Hg	Mercury
Hg <sup>0</sup>	Elemental Mercury
Hg <sup>2+</sup>	Oxidized Mercury
0.1.1.3 HgCl <sub>2</sub>	Mercury Chloride
0.1.1.4 HCl	Hydrochloric Acid
Independent standards-	NIST traceable or certified mercury standards from separate lot or manufactures than the calibration standards.
MDL-	Method detection limit, the minimum concentration of mercury that can be analyzed, measured and reported within 99 % confidence that the concentration is greater than zero.
Method 30B	a procedure, published by US EPA, for measuring total vapor phase mercury emissions from coal-fired combustion source

	using sorbent trap sampling and an extractive or thermal analytical technique.
NIST	National Institute of Standards and Technology, located in Gaithersburg, Maryland
Profile	A temperature control program, loaded into controller by Ohio Lumex Company prior to selling the system
RATA	Relative Accuracy Test Audit
Sorbent –	Media used in traps to adsorb mercury. May be halogenated or non-halogenated carbon.
Trap –	Glass tube packed with one, two or three beds of carbon sorbent held in place and separated by glass wool. The sample trap is placed in the sampling probe and flue gas is pulled through the sample trap. The carbon in the trap adsorbs mercury which is then used to determine the mercury concentration in the flue gas.

## 5 CALCULATIONS AND DATA ANALYSIS

\*All calculations and data analysis are explained in section 12.0 of Method 30B. These calculations are listed below:

Nomenclature. The terms used in the equations are defined as follows:

B = Breakthrough (%)

$B_{ws}$  = Moisture content of sample gas as measured by Method 4, percent/100

$C_a$  = Concentration of Hg for the sample collection period, for sorbent trap “a” ( $\mu\text{g}/\text{dscm}$ )

$C_b$  = Concentration of Hg for the sample collection period, for sorbent trap “b” ( $\mu\text{g}/\text{dscm}$ )

$C_d$  = Hg concentration, dry basis ( $\mu\text{g}/\text{dscm}$ )

$C_{rec}$  = Concentration of spiked compound measured ( $\mu\text{g}/\text{m}^3$ )

$C_w$  = Hg concentration, wet basis ( $\mu\text{g}/\text{m}^3$ )

$m_1$  = Mass of Hg measured on sorbent trap section 1 ( $\mu\text{g}$ )

$m_2$  = Mass of Hg measured on sorbent trap section 2 ( $\mu\text{g}$ )

$m_{\text{recovered}}$  = Mass of spiked Hg recovered in Analytical Bias or Field Recovery Test ( $\mu\text{g}$ )

$m_s$  = Total mass of Hg measured on spiked trap in Field Recovery Test ( $\mu\text{g}$ )

$m_{\text{spiked}}$  = Mass of Hg spiked in Analytical Bias or Field Recovery Test ( $\mu\text{g}$ )

$m_u$  = Total mass of Hg measured on unspiked trap in Field Recovery Test ( $\mu\text{g}$ )

R = Percentage of spiked mass recovered (%)

RD = Relative deviation between the Hg concentrations from traps "a" and "b" (%)

$v_s$  = Volume of gas sampled, spiked trap in Field Recovery Test (dscm)

$V_t$  = Total volume of dry gas metered during the collection period (dscm); for the purposes of this method, standard temperature and pressure are defined as 20° C and 760 mm Hg, respectively

$v_u$  = Volume of gas sampled, unspiked trap in Field Recovery Test (dscm)

12.2 Calculation of Spike Recovery (Analytical Bias Test). Calculate the percent recovery of  $\text{Hg}^0$  and  $\text{HgCl}_2$  using Equation 30B-1.

$$R = \frac{m_{\text{recovered}}}{m_{\text{spiked}}} \times 100 \quad \text{Eq. 30B-1}$$

12.3 Calculation of Breakthrough. Use Equation 30B-2 to calculate the percent breakthrough to the second section of the sorbent trap.

$$B = \frac{m_2}{m_1} \times 100 \quad \text{Eq. 30B-2}$$

12.4 Calculation of Hg Concentration. Calculate the Hg concentration measured with sorbent trap "a", using Equation 30B-3.

$$C_a = \frac{(m_1 + m_2)}{V_t} \quad \text{Eq. 30B-3}$$

For sorbent trap "b", replace " $C_a$ " with " $C_b$ " in Equation 30B-3. Report the average concentration, i.e.,  $\frac{1}{2}(C_a + C_b)$ .

12.5 Moisture Correction. Use Equation 30B-4 if your measurements need to be corrected to a wet basis.

$$C_w = C_d \times (1 - B_{wt}) \quad \text{Eq. 30B-4}$$

12.6 Calculation of Paired Trap Agreement. Calculate the relative deviation (RD) between the Hg concentrations measured with the paired sorbent traps using Equation 30B-5.

$$RD = \frac{|C_a - C_b|}{C_a + C_b} \times 100 \quad \text{Eq. 30B-5}$$

12.7 Calculation of Measured Spike Hg Concentration (Field Recovery Test). Calculate the measured spike concentration using Equation 30B-6.

$$C_{rec} = \frac{m_s}{v_s} - \frac{m_u}{v_u} \quad \text{Eq. 30B-6}$$

Then calculate the spiked Hg recovery, R, using Equation 30B-7.

$$R = \frac{C_{rec} \times v_s}{m_{spiked}} \times 100 \quad \text{Eq. 30B-7}$$

## 6 HEALTH AND SAFETY

- 6.1** If performing the test sampling, follow the Source/Plant safety protocol to ensure any hazards are avoided.
- 6.2** Proper protective equipment (lab coats, safety glasses, particulate respirator, nitrile gloves) should be worn while performing analysis.
- 6.3** Please refer to the provided Material Safety Data Sheets for every chemical used in order to avoid injury or reactions.

## 7 REFERENCES

1. "Thermal analysis for field sorbent trap mercury testing , Instruction hand book", Ohio Lumex Company Inc., 2006
2. Method 7473- " Mercury in solids and solutions by thermal decomposition, amalgamation, and atomic absorption spectrophotometry" , US EPA, 2007  
[www.epa.gov/sw-846/pdfs/7473.pdf](http://www.epa.gov/sw-846/pdfs/7473.pdf) .
3. Method 30B-"Determination of total vapor phase mercury emissions from coal-fired combustion sources using carbon sorbent traps", US EPA, 2008  
<http://www.epa.gov/ttn/emc/promgate/Meth30B.pdf>
4. Appendix K to Part 75-"Quality assurance and operating procedures for sorbent trap monitoring system", US EPA, 2005



9263 Ravenna Rd., Suite A-3

Twinsburg, OH, 44087

Toll Free: 888-876-2611

## **APPENDIX M: SPECIATION TRAP STANDARD OPERATING PROCEDURE**

Subject

Mercury Emissions Monitoring Program  
Speciation Sorbent Trap Sampling and Analysis Brief

Prepared by Analytical Laboratory of Ohio Lumex Company

Revised on January 15<sup>th</sup>, 2013

## 1 SPECIATION TRAP SAMPLING PROCEDURE RECOMMENDATIONS

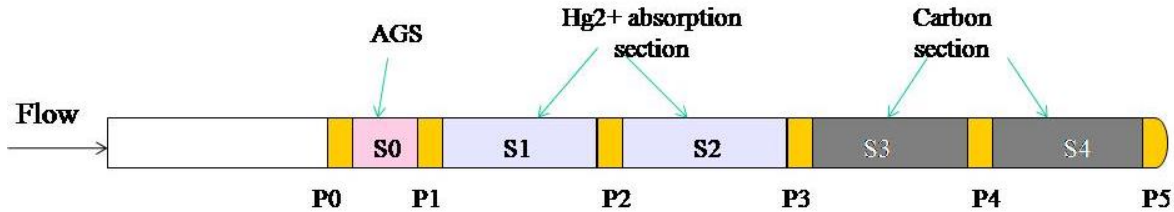

S0 = Acid Gas Scrubber (AGS)

S1 = Oxidized Mercury Analytical Bed (KCl)

S2 = Oxidized Mercury Breakthrough Bed (KCl)

S3 = Elemental Mercury Analytical Bed (Carbon)

S4 = Elemental Mercury Analytical Bed (Carbon)

Figure 1. Illustration of a Speciation Trap

There are two types of sampling locations and each has its own set of procedures and recommendations to follow. Please use the following procedures when sampling and analyzing Speciation traps.

### **FGD INLET/AFTER ESP, SCR, NSCR, or “DRY” STACK LOCATION:**

Traps should be sampled directly in the stack and not externally.

**TEMPERATURE:** The recommended trap temperature range for Speciation traps is between 220°F and 300°F. A cooling probe is only needed if you experience breakthroughs after 30 minutes of sampling (high SO<sub>2</sub> >1000ppm and/or SO<sub>3</sub> > 30ppm concentration) or if the flue gas temperature exceeds 350°F.

**FLOW RATE:** The recommended flow rate for Speciation traps is between 200cc/min and 250cc/min.

**SAMPLE VOLUME:** The recommended sample volume is close to 20L (depending on the source concentration.) This will provide sufficient mercury capture that can be easily distinguished from background levels and make analysis easy to perform.

**STARTING PUMPS:** The standard leak check procedure should be done and documented. The sampling pumps should be started before the probe is inserted into the duct. This is extremely important if there is positive pressure at the sample location or if you are using a mass flow controller to control the flow as it will prevent initial direct particulate entrainment on the front plug.

**SHROUD:** A shroud of 6 to 12 inches in length **MUST** be used to prevent particulate from entering the trap during the test run. Please use thin aluminum (available as roofing material in Home Depot) and a clamp to hold it to the end of the probe.

#### **WET STACK LOCATION (AFTER FGD):**

Traps should be sampled directly in the stack and not externally.

**TEMPERATURE:** The 4-8 inches before the first section on the trap must be heated inside of the probe to at least 230°F and must not exceed 300°F. This will ensure that any moisture remains in the vapor phase as it passes through the trap. It is also important to make sure the probe is fully heated before it is inserted into the stack.

**FLOW RATE:** The recommended flow rate is between 200cc/min and 250cc/min.

**SAMPLE VOLUME:** The recommended sample volume is approximately 20L (depending on the source concentration.) This will provide sufficient mercury capture that can be easily distinguished from background levels and make analysis easy to perform.

STARTING PUMPS: The pump should be started before the probe is inserted into the stack.

SHROUD: A shroud of 6 to 12 inches in length **MUST** be used to prevent direct moisture entrainment during the test run.

#### **ADDITIONAL NOTES:**

For inlet or dry stack locations, the shroud used must be made from a material that will not be affected by the high temperatures of the flue gas (as described above). The shroud used in a wet stack location can be made out of plastic tube or metal.

The distribution of oxidized mercury over the AGS and KCl sections is dependent upon many factors, but it is important to know that the plugs will capture oxidized mercury. The bond that is created between these sections and the oxidized mercury is a very weak physical bond and too much temperature or flow will cause these bonds to fail and result in breakthrough.

For both locations the front plug must have minimum amount of particulate or discoloration from white color.

Please note: Large amount of particulate or moisture on the front plug will skew the Total and speciation ratio and make the run invalid.

*We have found that the aforementioned sampling procedures will yield the most consistent and reproducible results.*

## 2 SPECIATION TRAP ANALYSIS PROCEDURE RECOMMENDATIONS

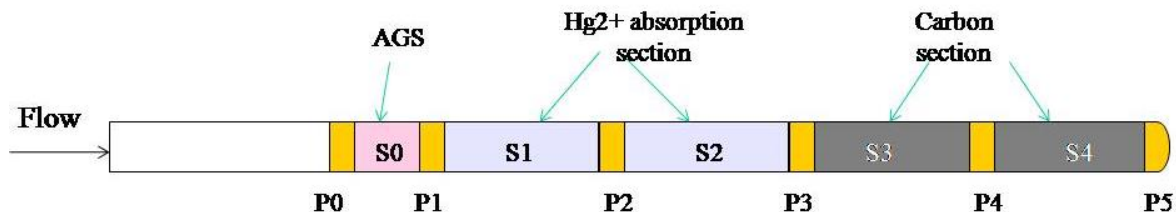

S0 = Acid Gas Scrubber (AGS)

S1 = Oxidized Mercury Analytical Bed (KCl)

S2 = Oxidized Mercury Breakthrough Bed (KCl)

S3 = Elemental Mercury Analytical Bed (Carbon)

S4 = Elemental Mercury Analytical Bed (Carbon)

Figure 1. Illustration of a Speciation Trap

*For full analytical procedure, please refer to the Speciation Traps Analytical SOP.*

1. Clean the furnace and analyzer windows before heating up the furnace. Calibrate analyzer as per method 30B using carbon as calibration substrate. Change temperature set point on Watlow controller (use up/down arrow keys) to 590°C. The furnace must look almost dark if looking inside through the ladle entry hole. Only one calibration curve is required for the analysis of AGS, KCl, and carbon. **Cover all sections with soda except for the AGS section.** Soda must be pressed using a sheet of Aluminum Foil. **Never place KCL on top of carbon.** Use upgraded pump station and set flow rate to 0.5 Lpm. Use low level calibration from 2ng to 20 ng and use averaged calibration coefficient in calculations.

2. Please “burn off” ladles before you proceed with analysis. After heating in the furnace, let the ladle cool before cleaning off the residue. Remove sticking residue by gently scraping the ladle or washing it in water. Melting or fusing of the KCL with soda indicates overheating so you

must drop the temperature on the controller 10 or 20 degrees. Wash ladle with water at the end of the day of testing. **Use ceramic ladles.**

3. Average analysis time is 180-220 seconds. Wait for KCL peak to come back to baseline (it will "tail"! ). Extended analysis time in the furnace (over 300 sec) indicates that the temperature is too low. Manually integrate the peaks to ensure only the captured sampled mercury is accounted for (not the baseline noise).
4. Do not pull the glass wool through the trap (ash bonded mercury will bias the results.) Cut the traps with a dremel fitted with a diamond wheel blade right before the front plug.
5. Wrap the plug wool in aluminum foil before ladle goes in the furnace and wear rubber gloves to ensure there is no additional mercury transferred to the plugs. Test the foil for mercury adsorbed from air and discard if positive. Test the carbon used in calibration. Do not leave carbon open to lab air for long time.
6. You may combine first and second wool plugs (P0, P1) to save on analysis time. You may analyze section 0 (acid gas scrubber) and section 1 (1<sup>st</sup> bed of KCL) together. P2 and section 2 must be analyzed separately to determine if breakthrough is present.
7. The remaining carbon sections are to be analyzed just like a 30B sorbent trap.
8. Oxidized mercury is equal to the loading on section 0 (acid gas scrubber), section 1 (KCL), and section 2 (KCL breakthrough) as well as (P0, P1, P2) combined. If breakthrough is experienced, sampling conditions must be altered to prevent this from happening again. Elemental mercury is equal to the loading on section 3 and section 4 as well as (P3, P4, P5) combined.
9. Try not to spill soda in the oven. Clean oven (when still hot) at the end of the day with vacuum cleaner nozzle approaching from the ladle intake port. Disconnect silicone lines (before filter) to provide unrestricted flow back through the Furnace. Connect lines back.

## Appendix N:

### Analyzing Coal, Ash, Soils, and Other Solids with the RA-915M/RP-M324 Analyzer

Coal, ash, soils, and other solid samples can be analyzed and quantified easily using the Ohio Lumex RA-915M/RP-M324 Sorbent Trap Mercury Analyzer. Here are some guidelines and tips to make the analysis go smoothly.

- Use the instrument's most sensitive setting (usually Profile #1)
- Calibrate the instrument as you would for trap analysis.
- The coal to be analyzed should be reasonably pulverized.
- Place the sample ladle on a suitable balance (a "3-place" balance that can measure down to 0.000 g) and "tare" the ladle.
- Evenly distribute 100-200 mg of the coal sample on the bottom of the ladle and record the mass.
- Remember, coal has relatively low mercury content so enough needs to be added in order to form a good peak, but using too much will produce a lot of smoke which will overwhelm the filtering layers described below. A mass of 100-200 mg has proven to be a suitable amount.
- On top of the coal, add a layer of iodinated carbon to cover the coal. This layer of carbon filters the smoke and helps make a well-defined peak. Do not use too much; make sure to leave room for the next step!
- On top of this, add a heavy layer of sodium carbonate.
- Wipe excess sodium carbonate off the top then pack the sample down using a clean piece of aluminum foil.
- Add some more sodium carbonate and again compress this with the aluminum foil. Be careful not to use so much that you spill any in the furnace.
- In the analyzer's software spreadsheet window, enter the sample's description in the appropriate cell and enter the sample's mass in grams in the cell labeled

“Mass/Volume.” This way, the software will calculate the concentration of the mercury in your sample in “ng/g” (ppb).

- Analyze the sample as usual; press “Mark” and insert the ladle into the furnace.
- This analysis will take longer than a typical analysis, usually about 120 seconds. The peak may have 2 apexes as the elemental mercury is released, followed by the oxidized mercury.
- When the sample is done and the signal returns back to normal, press the “Mark and Integrate” button.
- The calculated sample concentration will be expressed in “ng/g” (ppb).
- Keep in mind that the results will be “wet.” A separate analysis must be performed to get a “dry-weight” result.
- Coal is not very homogenous. For best results analyze each lot sample three times.
- Ash samples are analyzed in a similar fashion but are less of a problem because of the ash’s high mercury concentration and minimal smoke production. Weigh out the ash sample as stated above but do not worry about covering the sample with carbon or sodium carbonate.
- Soil Samples are analyzed similarly to Ash samples.
- This technique can be used to analyze other solid or “complex” samples if they are “within reason.” Ohio Lumex will not be responsible for damage caused by the analysis of inappropriate samples. If you are unsure of the sample, use caution, start with small amounts, and/or call Ohio Lumex Technical Support.



# Ohio Lumex Company

9263 Ravenna Rd., Unit A-3

Twinsburg, Ohio 44087

Toll Free: (888) 876 2611, (330) 405 0837

Fax: (330) 405 0847

[www.ohiolumex.com](http://www.ohiolumex.com)

## Warranty

**Warranty:** Ohio Lumex warrants that its products will be free from defects in material and workmanship for a period of one (1) year from the date of shipment, provided the product is maintained and operated consistent with Ohio Lumex's guidelines. This warranty does not apply to consumables such as Mercury Lamps, Scrubbers, Calibration Cells, Filters and Heater Cartridges or parts delivered by Ohio Lumex but manufactured by others. Ohio Lumex does not warrant that the operation of products will be uninterrupted or error free. Ohio Lumex will repair or replace, at no charge, products which are defective and returned to Ohio Lumex within one (1) year of delivery, or at Ohio Lumex's sole option, refund Customer's purchase price.

THIS WARRANTY IS EXPRESSLY GIVEN IN LIEU OF ANY AND ALL OTHER EXPRESS OR IMPLIED WARRANTIES, INCLUDING ANY IMPLIED WARRANTY OR MERCHANTABILITY OR FITNESS FOR A PARTICULAR PURPOSE.

**Exclusions:** The warranty of Ohio Lumex does not cover the following terms and events:

- a. Failure of mechanical parts due to normal wear and tear.
- b. Electrical components that deteriorate due to age, such as lamps and the like.
- c. Any defect caused by misuse, negligence, accident or improper installation by the Customer.
- d. Certain parts such as mercury lamps, quartz windows, filters, heater cartridges and ladles, are expendable in normal use and their service life is unpredictable. These items are covered by this warranty for ninety (90) days only from the delivery date to the customer site.
- e. Damage to Product resulting from failure of the Customer to provide the required conditions for proper operation of the Product.
- f. Customer-induced contamination.

**Warranty Claims:** A defective product will be shipped to Ohio Lumex Co., Inc., 9263 Ravenna Road, Unit A-3, Twinsburg, Ohio, 44087. All products returned for warranty work must be assigned a Return Authorization Number (RA #) by Ohio Lumex before the product is returned to Ohio Lumex. Products returned to the factory without an RA # will not be accepted. The cost of removal, reinstall and shipment to Ohio Lumex will be the responsibility of the Customer; cost of return shipment to the Customer will be paid by Ohio Lumex. Repair or replacement of a defective item shall not extend the initial warranty term. Ohio Lumex shall have the right of disposal of items replaced by it. Ohio Lumex may, at its discretion, travel to the location of installation to handle warranty claims for products that Ohio Lumex installed.

**Exclusive Remedy; Limitation of Liability:** THE REMEDY PROVIDED FOR HEREIN SHALL BE THE EXCLUSIVE REMEDY FOR ANY BREACH OF WARRANTY OR ANY CLAIM ARISING IN ANY WAY OUT OF THE MANUFACTURE, SALE OR USE OF ITS PRODUCTS.

OHIO LUMEX SHALL NOT BE LIABLE FOR ANY LOSS OR DAMAGE DIRECTLY OR INDIRECTLY ARISING FROM THE MANUFACTURE, SALE OR USE OF ITS PRODUCTS OR ITS PERFORMANCE OF WORK, INCLUDING LABORATORY ANALYSIS OR ONSITE WORK. IN NO EVENT SHALL OHIO LUMEX BE LIABLE FOR ANY CONSEQUENTIAL, INDIRECT, SPECIAL, INCIDENTAL OR ANY OTHER DAMAGES OF ANY NATURE WHATSOEVER.

**Extended Warranty & Service Agreement (optional, not applicable to all products):** The terms of the warranty extend for an additional one (1) year beyond the standard one-year warranty period. In addition, the service agreement consists of: one annual calibration, cleaning and adjustments to optics and electronics, one internal rechargeable battery replacement, one zero mercury filter replacement, and one intake port filter replacement. The Extended Warranty & Service Agreement commences at the end of the one-year standard warranty period and must be pre-paid.

# SAFETY DATA SHEET

## 1. Identification

**Product identifier:** SODIUM CARBONATE

**Other means of identification**

**Product No.:** 3642, 7528, 7527, 7521, 3606, 3605, 3604, 3602, 4923, 29704, 29420

**Recommended use and restriction on use**

**Recommended use:** Not available.

**Restrictions on use:** Not known.

**Manufacturer/Importer/Supplier/Distributor information**

**Manufacturer**

**Company Name:** Avantor Performance Materials, Inc.  
**Address:** 3477 Corporate Parkway, Suite 200  
Center Valley, PA 18034

**Telephone:** Customer Service: 855-282-6867

**Fax:**  
**Contact Person:** Environmental Health & Safety  
**e-mail:** info@avantormaterials.com

**Emergency telephone number:**

24 Hour Emergency: 908-859-2151

Chemtrec: 800-424-9300

## 2. Hazard(s) identification

**Hazard classification**

**Health hazards**

Acute toxicity (Inhalation - dust and mist)	Category 4
Skin corrosion/irritation	Category 2
Serious eye damage/eye irritation	Category 2A
Specific target organ toxicity - single exposure	Category 3

**Unknown toxicity**

Acute toxicity, dermal	100 %
------------------------	-------

**Unknown toxicity**

Chronic hazards to the aquatic environment	100 %
--	-------

**Label elements**

**Hazard symbol:**



<b>Signal word:</b>	Warning
<b>Hazard statement:</b>	Harmful if inhaled. Causes skin irritation. Causes serious eye irritation. May cause respiratory irritation.
<b>Precautionary statement</b>	
<b>Prevention:</b>	Avoid breathing dust/fume/gas/mist/vapors/spray. Wear protective gloves/protective clothing/eye protection/face protection. Use only outdoors or in a well-ventilated area. Wash hands thoroughly after handling.
<b>Response:</b>	IF INHALED: Remove victim to fresh air and keep at rest in a position comfortable for breathing. Call a POISON CENTER/doctor if you feel unwell. IF IN EYES: Rinse cautiously with water for several minutes. Remove contact lenses, if present and easy to do. Continue rinsing. If eye irritation persists: Get medical advice/attention. IF ON SKIN: Wash with plenty of water. Take off contaminated clothing and wash it before reuse. If skin irritation occurs: Get medical advice/attention. Specific treatment (see this label).
<b>Storage:</b>	Store in a well-ventilated place. Keep container tightly closed. Store locked up.
<b>Disposal:</b>	Dispose of contents/container to an appropriate treatment and disposal facility in accordance with applicable laws and regulations, and product characteristics at time of disposal.
<b>Other hazards which do not result in GHS classification:</b>	None.

**3. Composition/Information on Ingredients**

**Substances**

Chemical identity	Common name and synonyms	CAS number	Content in percent (%)*
SODIUM CARBONATE		497-19-8	99 - 100%

\* All concentrations are percent by weight unless ingredient is a gas. Gas concentrations are in percent by volume.

**4. First-aid measures**

<b>General information:</b>	Get medical advice/attention if you feel unwell. Show this safety data sheet to the doctor in attendance.
<b>Ingestion:</b>	Rinse mouth. Call a POISON CENTER or doctor/physician if you feel unwell.
<b>Inhalation:</b>	Move to fresh air. Get medical attention.
<b>Skin contact:</b>	Wash skin thoroughly with soap and water. Get medical attention if symptoms occur.
<b>Eye contact:</b>	Immediately flush with plenty of water for at least 15 minutes. If easy to do, remove contact lenses. Get medical attention if symptoms persist.

**Most important symptoms/effects, acute and delayed**

**Symptoms:** Harmful if inhaled. Irritating to eyes, respiratory system and skin.

**Indication of immediate medical attention and special treatment needed**

**Treatment:** Treat symptomatically. Symptoms may be delayed.

**5. Fire-fighting measures**

**General fire hazards:** No unusual fire or explosion hazards noted.

**Suitable (and unsuitable) extinguishing media**

**Suitable extinguishing media:** Use fire-extinguishing media appropriate for surrounding materials.

**Unsuitable extinguishing media:** None known.

**Specific hazards arising from the chemical:** None known.

**Special protective equipment and precautions for firefighters**

**Special fire fighting procedures:** Move containers from fire area if you can do so without risk. Use water spray to keep fire-exposed containers cool.

**Special protective equipment for fire-fighters:** Firefighters must use standard protective equipment including flame retardant coat, helmet with face shield, gloves, rubber boots, and in enclosed spaces, SCBA.

**6. Accidental release measures**

**Personal precautions, protective equipment and emergency procedures:** Keep unauthorized personnel away. Keep upwind. Ventilate closed spaces before entering them. Avoid inhalation of dust. Do not touch damaged containers or spilled material unless wearing appropriate protective clothing. See Section 8 of the MSDS for Personal Protective Equipment.

**Methods and material for containment and cleaning up:** Sweep up and place in a clearly labeled container for chemical waste. Clean surface thoroughly to remove residual contamination.

**Notification Procedures:** Inform authorities if large amounts are involved.

**Environmental precautions:** Do not contaminate water sources or sewer. Prevent further leakage or spillage if safe to do so.

**7. Handling and storage**

**Precautions for safe handling:** Avoid inhalation of dust. Avoid contact with eyes, skin, and clothing. Do not taste or swallow. Use only with adequate ventilation. Wash hands thoroughly after handling. See Section 8 of the MSDS for Personal Protective Equipment.

**Conditions for safe storage, including any incompatibilities:** Keep container tightly closed. Store in a well-ventilated place. Store in a dry place. Store locked up.

## 8. Exposure controls/personal protection

### Control parameters

#### Occupational exposure limits

None of the components have assigned exposure limits.

#### Appropriate engineering controls

No data available.

### Individual protection measures, such as personal protective equipment

<b>General information:</b>	Good general ventilation (typically 10 air changes per hour) should be used. Ventilation rates should be matched to conditions. If applicable, use process enclosures, local exhaust ventilation, or other engineering controls to maintain airborne levels below recommended exposure limits. If exposure limits have not been established, maintain airborne levels to an acceptable level. An eye wash and safety shower must be available in the immediate work area.
<b>Eye/face protection:</b>	Wear safety glasses with side shields (or goggles).
<b>Skin protection</b>	
<b>Hand protection:</b>	Chemical resistant gloves
<b>Other:</b>	Wear suitable protective clothing.
<b>Respiratory protection:</b>	In case of inadequate ventilation use suitable respirator. Air-purifying respirator with a high efficiency particulate filter.
<b>Hygiene measures:</b>	Provide eyewash station and safety shower. Always observe good personal hygiene measures, such as washing after handling the material and before eating, drinking, and/or smoking. Routinely wash work clothing to remove contaminants. Discard contaminated footwear that cannot be cleaned.

## 9. Physical and chemical properties

### Appearance

<b>Physical state:</b>	Solid
<b>Form:</b>	Powder
<b>Color:</b>	White
<b>Odor:</b>	Odorless
<b>Odor threshold:</b>	No data available.
<b>pH:</b>	11.4 - 11.7 (25 °C) Aqueous solution
<b>Melting point/freezing point:</b>	851 °C
<b>Initial boiling point and boiling range:</b>	Decomposes
<b>Flash Point:</b>	Not applicable
<b>Evaporation rate:</b>	No data available.
<b>Flammability (solid, gas):</b>	No data available.
<b>Upper/lower limit on flammability or explosive limits</b>	
<b>Flammability limit - upper (%):</b>	No data available.
<b>Flammability limit - lower (%):</b>	No data available.
<b>Explosive limit - upper (%):</b>	No data available.
<b>Explosive limit - lower (%):</b>	No data available.
<b>Vapor pressure:</b>	No data available.
<b>Vapor density:</b>	No data available.
<b>Relative density:</b>	2.53 (20 °C)
<b>Solubility(ies)</b>	
SDS_US - SDS000000960	

<b>Solubility in water:</b>	Soluble
<b>Solubility (other):</b>	No data available.
<b>Partition coefficient (n-octanol/water):</b>	No data available.
<b>Auto-ignition temperature:</b>	No data available.
<b>Decomposition temperature:</b>	No data available.
<b>Viscosity:</b>	No data available.

**Other information**

<b>Molecular weight:</b>	105.99 g/mol (CH <sub>2</sub> O <sub>3</sub> .2Na)
--------------------------	--

**10. Stability and reactivity**

<b>Reactivity:</b>	No dangerous reaction known under conditions of normal use.
<b>Chemical stability:</b>	Material is stable under normal conditions.
<b>Possibility of hazardous reactions:</b>	Hazardous polymerization does not occur.
<b>Conditions to avoid:</b>	Excessive heat. Moisture.
<b>Incompatible materials:</b>	Strong oxidizing agents. Strong acids. Aluminum.
<b>Hazardous decomposition products:</b>	Sodium oxides Carbon monoxide Carbon dioxide

**11. Toxicological information**

**Information on likely routes of exposure**

<b>Ingestion:</b>	May be harmful if swallowed.
<b>Inhalation:</b>	Irritating to respiratory system.
<b>Skin contact:</b>	Causes skin irritation.
<b>Eye contact:</b>	Causes serious eye irritation.

**Information on toxicological effects**

**Acute toxicity (list all possible routes of exposure)**

<b>Oral</b>	
<b>Product:</b>	LD 50 (Rat): 4,090 mg/kg
<b>Dermal</b>	
<b>Product:</b>	No data available.
<b>Inhalation</b>	
<b>Product:</b>	LC 50 (Mouse, 2 h): 1.2 mg/l LC 50 (Guinea pig, 2 h): 0.8 mg/l
<b>Repeated dose toxicity</b>	
<b>Product:</b>	No data available.

**Skin corrosion/irritation**

<b>Product:</b>	Causes skin irritation.
-----------------	-------------------------

**Serious eye damage/eye irritation**

<b>Product:</b>	Causes serious eye irritation.
-----------------	--------------------------------

**Respiratory or skin sensitization**

**Product:** Not a skin sensitizer.

**Carcinogenicity**

**Product:** This substance has no evidence of carcinogenic properties.

**IARC Monographs on the Evaluation of Carcinogenic Risks to Humans:**

No carcinogenic components identified

**US. National Toxicology Program (NTP) Report on Carcinogens:**

No carcinogenic components identified

**US. OSHA Specifically Regulated Substances (29 CFR 1910.1001-1050):**

No carcinogenic components identified

**Germ cell mutagenicity**

**In vitro**

**Product:** No data available.

**In vivo**

**Product:** No data available.

**Reproductive toxicity**

**Product:** No components toxic to reproduction

**Specific target organ toxicity - single exposure**

**Product:** Respiratory tract irritation.

**Specific target organ toxicity - repeated exposure**

**Product:** None known.

**Aspiration hazard**

**Product:** Not classified

**Other effects:**

None known.

**12. Ecological information**

**Ecotoxicity:**

**Acute hazards to the aquatic environment:**

**Fish**

**Product:** LC 50 (Bluegill (*Lepomis macrochirus*), 96 h): 300 mg/l

**Aquatic invertebrates**

**Product:** EC 50 (Water flea (*Ceriodaphnia dubia*), 48 h): 156.6 mg/l

**Chronic hazards to the aquatic environment:**

**Fish**

**Product:** No data available.

**Aquatic invertebrates**

**Product:** No data available.

**Toxicity to Aquatic Plants**

**Product:** No data available.

**Persistence and degradability**

**Biodegradation**

**Product:** Expected to be readily biodegradable.

SDS\_US - SDS000000960

**BOD/COD ratio**  
**Product:** No data available.

**Bioaccumulative potential**  
**Bioconcentration factor (BCF)**  
**Product:** The product is not bioaccumulating.

**Partition coefficient n-octanol / water (log Kow)**  
**Product:** No data available.

**Mobility in soil:** The product is water soluble and may spread in water systems.

**Other adverse effects:** The product components are not classified as environmentally hazardous. However, this does not exclude the possibility that large or frequent spills can have a harmful or damaging effect on the environment.

### 13. Disposal considerations

**Disposal instructions:** Discharge, treatment, or disposal may be subject to national, state, or local laws.

**Contaminated packaging:** Since emptied containers retain product residue, follow label warnings even after container is emptied.

### 14. Transport information

**DOT**  
Not regulated.

**IMDG**  
Not regulated.

**IATA**  
Not regulated.

### 15. Regulatory information

#### US federal regulations

**TSCA Section 12(b) Export Notification (40 CFR 707, Subpt. D)**  
**US. OSHA Specifically Regulated Substances (29 CFR 1910.1001-1050)**  
None present or none present in regulated quantities.

**CERCLA Hazardous Substance List (40 CFR 302.4):**  
None present or none present in regulated quantities.

#### Superfund amendments and reauthorization act of 1986 (SARA)

##### Hazard categories

Acute (Immediate)  Chronic (Delayed)  Fire  Reactive  Pressure Generating

**SARA 302 Extremely hazardous substance**  
None present or none present in regulated quantities.

**SARA 304 Emergency release notification**  
None present or none present in regulated quantities.

SARA 311/312 Hazardous chemical Chemical Identity	Threshold Planning Quantity
SODIUM CARBONATE	500 lbs

**SARA 313 (TRI reporting)**

None present or none present in regulated quantities.

**Clean Water Act Section 311 Hazardous Substances (40 CFR 117.3)**

None present or none present in regulated quantities.

**Clean Air Act (CAA) Section 112(r) Accidental Release Prevention (40 CFR 68.130):**

None present or none present in regulated quantities.

**US state regulations**

**US. California Proposition 65**

No ingredient regulated by CA Prop 65 present.

**US. New Jersey Worker and Community Right-to-Know Act**

No ingredient regulated by NJ Right-to-Know Law present.

**US. Massachusetts RTK - Substance List**

No ingredient regulated by MA Right-to-Know Law present.

**US. Pennsylvania RTK - Hazardous Substances**

No ingredient regulated by PA Right-to-Know Law present.

**US. Rhode Island RTK**

No ingredient regulated by RI Right-to-Know Law present.

**Inventory Status:**

Australia AICS:	On or in compliance with the inventory
Canada DSL Inventory List:	On or in compliance with the inventory
EINECS, ELINCS or NLP:	On or in compliance with the inventory
Japan (ENCS) List:	On or in compliance with the inventory
China Inv. Existing Chemical Substances:	Not in compliance with the inventory.
Korea Existing Chemicals Inv. (KECI):	On or in compliance with the inventory
Canada NDSL Inventory:	Not in compliance with the inventory.
Philippines PICCS:	On or in compliance with the inventory
US TSCA Inventory:	On or in compliance with the inventory
New Zealand Inventory of Chemicals:	On or in compliance with the inventory
Japan ISHL Listing:	On or in compliance with the inventory
Japan Pharmacopoeia Listing:	Not in compliance with the inventory.

**16. Other information, including date of preparation or last revision**

**NFPA Hazard ID**

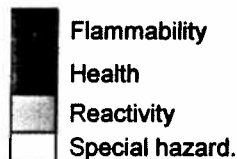

Hazard rating: 0 - Minimal; 1 - Slight; 2 - Moderate; 3 - Serious; 4 - Severe

Issue date: 05-12-2014  
SDS\_US - SDS000000960

**Revision date:** No data available.

**Version #:** 1.0

**Further information:** No data available.

**Disclaimer:** THE INFORMATION PRESENTED IN THIS MATERIAL SAFETY DATA SHEET (MSDS/SDS) WAS PREPARED BY TECHNICAL PERSONNEL BASED ON DATA THAT THEY BELIEVE IN THEIR GOOD FAITH JUDGMENT IS ACCURATE. HOWEVER, THE INFORMATION PROVIDED HEREIN IS PROVIDED "AS IS," AND AVANTOR PERFORMANCE MATERIALS MAKES AND GIVES NO REPRESENTATIONS OR WARRANTIES WHATSOEVER, AND EXPRESSLY DISCLAIMS ALL WARRANTIES REGARDING SUCH INFORMATION AND THE PRODUCT TO WHICH IT RELATES, WHETHER EXPRESS, IMPLIED, OR STATUTORY, INCLUDING WITHOUT LIMITATION, WARRANTIES OF ACCURACY, COMPLETENESS, MERCHANTABILITY, NON-INFRINGEMENT, PERFORMANCE, SAFETY, SUITABILITY, STABILITY, AND FITNESS FOR A PARTICULAR PURPOSE, AND ANY WARRANTIES ARISING FROM COURSE OF DEALING, COURSE OF PERFORMANCE, OR USAGE OF TRADE. THIS MSDS/SDS IS INTENDED ONLY AS A GUIDE TO THE APPROPRIATE PRECAUTIONARY HANDLING OF THE MATERIAL BY A PROPERLY TRAINED PERSON USING THIS PRODUCT, AND IS NOT INTENDED TO BE COMPREHENSIVE AS TO THE MANNER AND CONDITIONS OF USE, HANDLING, STORAGE, OR DISPOSAL OF THE PRODUCT. INDIVIDUALS RECEIVING THIS MSDS/SDS MUST ALWAYS EXERCISE THEIR OWN INDEPENDENT JUDGMENT IN DETERMINING THE APPROPRIATENESS OF SUCH ISSUES. ACCORDINGLY, AVANTOR PERFORMANCE MATERIALS ASSUMES NO LIABILITY WHATSOEVER FOR THE USE OF OR RELIANCE UPON THIS INFORMATION. NO SUGGESTIONS FOR USE ARE INTENDED AS, AND NOTHING HEREIN SHALL BE CONSTRUED AS, A RECOMMENDATION TO INFRINGE ANY EXISTING PATENTS OR TO VIOLATE ANY FEDERAL, STATE, LOCAL, OR FOREIGN LAWS. AVANTOR PERFORMANCE MATERIALS REMINDS YOU THAT IT IS YOUR LEGAL DUTY TO MAKE ALL INFORMATION IN THIS MSDS/SDS AVAILABLE TO YOUR EMPLOYEES.

---

---

# MATERIAL SAFETY DATA SHEET

Ohio Lumex Company, Inc  
9263 Ravenna Rd Unit A-3  
Twinsburg, Ohio 44087  
Phone 330 405 0837  
Emergency Phone 330 405 0837

---

---

**Section I - PRODUCT NAME**  
Activated Carbon Type :K 2050-1

---

---

## **Section II - HAZARDOUS INGREDIENTS**

---

---

<u>Name</u>	<u>CAS Number</u>	<u>% By Weight</u>
1. Carbon Activated Carbon (Non-Regulated)	7440-44-0	>90
2. Iodine	7553-56-2	<10

---

---

(ACGIH, OSHA and other TLV are not applicable for activated carbon.)

**Caution:** Wet activated carbon removes oxygen from air causing a severe hazard to workers inside carbon vessels and enclosed or confined spaces. Before entering such an area, sampling and work procedures for low oxygen levels should be taken to ensure ample oxygen availability, observing all local, state and federal regulations.

---

---

## **SECTION III - PHYSICAL DATA**

---

---

Boiling Point (°F) : N/A	Specific Gravity (water=1) : 1.9-2.2
Vapor Pressure : N/A	Packing Density (g/cc) : 0.4-0.8
Solubility In Water : N/A	pH : N/A
Appearance & Odor : Black granular or powder odorless	

---

---

## **SECTION IV - FIRE & EXPLOSION HAZARD DATA**

---

---

Flash Point : N/A LEL : N/A Ignition Temperature (°C) : 300  
Flammable Limits : N/A UEL : N/A

Extinguishing Media : Flood with plenty of water or inert gas, such as N<sub>2</sub>  
and CO<sub>2</sub>  
Special Fire Fighting Procedure: None

---

---

## **SECTION V - REACTIVITY**

---

---

Stability : Stable  
Hazardous Polymerization : Will not occur  
Hazardous Decomposition : CO may be generated in the event of fire

---

---

Condition To Avoid : Contact with strong oxidizers, such as ozone, liquid oxygen, chlorine, permanganate and ketone may cause fire.

Incompatibility : Avoid contact with high concentration of ketone in air or liquid.

---

---

**SECTION VI - HEALTH HAZARD DATA**

---

---

Carcinogenicity : N/A                      Skin : N/A                      Ingestion : N/A  
Acute or Chronic : N/A                      NTP : N/A                      IARC Monograph : N/A  
Inhalation : Dust may be inhaled                      OSHA : N/A

Signs & Symptoms of Exposure : Slight irritation of eyes and nose may result from contact with carbon fines  
Medical Conditions Generally Aggravated By Exposure : N/A

---

---

**SECTION VII - EMERGENCY & FIRST AID PROCEDURE**

---

---

Skin : N/A                      Ingestion : N/A                      Inhalation : N/A  
Eye : Flush with plenty of water at least for 15 minutes

Follow-up with physician exam if necessary.

---

---

**SECTION VIII - SAFE HANDLING & STORAGE**

---

---

Protective Gloves : Rubber Gloves                      Protective Clothing : Not required  
Eye Protection : Safety Glasses                      Respirator Protection: A NIOSH approved particulate filter  
Ventilation : Local & Mechanical exhaust recommended  
Storage & Handling : Avoid generation of dust and fines during handling

---

---

**SECTION IX - SPILL OR LEAK PROCEDURE**

---

---

Notify EPA If Product Spills : Report in accordance with local, state and federal regulations

Cleaning Procedure : Sweep up unused carbon and discard in refuse container or repackage for further use.

---

---

**SECTION X - OTHER OPERATIONAL INSTRUCTIONS**

---

---

---

---

Prepared By : Joseph Siperstein

Date : February 24, 2006

---

---

*OHIO LUMEX MAKES NO WARRANTY WITH RESPECT HERETO AND DISCLAIMS ALL LIABILITY FROM RELIANCE THEREON*